



**TRANSMISSION PROTECTION & CONTROL
POINT OF CONTACT REQUIREMENTS FOR
CUSTOMER-OWNED FACILITIES (138 KV & 69 KV)**

EU00513844
Revision: 4
Effective Date: 10/1/2018
Sheet 1 of 86

**PPL ELECTRIC UTILITIES
POINT OF CONTACT REQUIREMENTS FOR
TRANSMISSION VOLTAGE CUSTOMER-OWNED FACILITIES
(138 KV & 69 KV)**

Contributing Parties:

Signature Department Date

Primary Group

Preparer: Ken W. Schuette _____ 9/28/2018
Reviewer: Nathaniel Houtz _____ 9/28/2018
Approver: Enrique Rodriguez-Arce _____ 10/1/2018

Interfacing Groups

Group 1: _____
Group 2: _____
Group 3: _____

Document Information:

Location Code: R073 _____
Sorts: W _____
Supersedes: _____

This document is the property of PPL Electric Utilities and contains proprietary and confidential information which must not be duplicated, used, or disclosed without written authorization from PPL Electric Utilities.



**TRANSMISSION PROTECTION & CONTROL
POINT OF CONTACT REQUIREMENTS FOR
CUSTOMER-OWNED FACILITIES (138 KV & 69 KV)**

EU00513844
Revision: 4
Effective Date: 10/1/2018
Sheet 2 of 86

Record of All Issued Revisions:

Revision	Pages	Section	Description	Issue Date
4	All	All	Revised section of transformer connections and vector diagrams, and minor corrections through the document Prepared by: Ken W. Schuette Reviewed by: Nathaniel Houtz	10/1/2018
3	All	All	Revised to address only 69 and 138 kV; added MOLBAB for PPL sectionalizing and added maintenance list Prepared by: KWS, JJM Reviewed by: JJS, KWB, EDL	10/31/2016
2	---	---	Updated Sections 1.2, 4.5.3, 4.5.4, and Added Appendix 5.0 Prepared by: Randy Vresko Reviewed by: GWL	10/16/2014
1	All	All	Reformatted and updated Customer POC document Prepared by: Ken W. Schuette Reviewed by: Daniel Chaply, David S. Price	4/27/2007

Primary Distribution:

RC 0905 Relay Engineering

RC 0665 Relay Test

RC 0883 Substation Engineering

RC 0661 Power Dispatch

RC 0601 T&S Asset Management

RC 0711 Major Accounts

RC 0880 T&S Eng & Maint Standards



**TRANSMISSION PROTECTION & CONTROL
POINT OF CONTACT REQUIREMENTS FOR
CUSTOMER-OWNED FACILITIES (138 KV & 69 KV)**

EU00513844
Revision: 4
Effective Date: 10/1/2018
Sheet 3 of 86

Table of Contents

FOREWORD	5
SECTION 1 OVERVIEW OF INTERCONNECTING UTILITY AND CUSTOMER FACILITIES	6
1.1 INITIATING A REQUEST TO ADD OR MODIFY CUSTOMER CONNECTIONS	6
1.2 POINT OF CONTACT - GENERAL	6
1.3 METERING OF ELECTRIC SERVICE	8
1.4 DEFINITIONS	8
1.5 POWER TRANSFORMER CONNECTIONS AND VECTOR DIAGRAMS	9
1.6 BASIC INSULATION LEVELS AND CLEARANCES	12
1.7 VOLTAGE LEVELS AND VARIATION	12
1.8 CUSTOMER-OWNED TRANSFORMER SELECTION (nominal 138-12 kV and 69-12 kV)	13
1.9 INSTALLATIONS INVOLVING 12 KV SUPPLY	13
1.10 INSTALLATIONS INVOLVING 69 or 138 KV SUPPLY	13
1.11 INSTALLATIONS INVOLVING CUSTOMER-OWNED GENERATION	13
SECTION 2 CUSTOMER RESPONSIBILITIES	14
69 KV or 138 KV SUPPLY – CUSTOMER RESPONSIBILITIES	14
SECTION 3 PPL EU TRANSMISSION LINE AND SUBSTATION REQUIREMENTS	16
SECTION 4 SUBSTATION PHYSICAL ELECTRICAL AND EQUIPMENT REQUIREMENTS	18
4.1 SUBSTATION ORIENTATION AND PPL EU TRANSMISSION LINE	18
4.2 SUBSTATION LINE DEAD-END STRUCTURE	18
4.3 GROUNDING REQUIREMENTS	18
4.4 GROUND GRID TESTING	19
4.5 POINT OF CONTACT SWITCHING DIAGRAMS AND NOTES	19
4.6 EQUIPMENT AND MATERIAL	23
SECTION 5 PROTECTION AND CONTROL REQUIREMENTS	26
5.1 SINGLE LINE SUPPLY SUBSTATION – NO ALTERNATE SOURCE (TYPE A) (See diagram on page 31)	26
5.2 TWO LINE SUPPLY SUBSTATION - OPEN TIE BETWEEN SOURCES (TYPE AA) (See diagram on page 40)	32
5.3 TWO LINE SUPPLY SUBSTATION - CLOSED TIE BETWEEN SOURCES (TYPE B) (See diagram on page 49)	41



**TRANSMISSION PROTECTION & CONTROL
POINT OF CONTACT REQUIREMENTS FOR
CUSTOMER-OWNED FACILITIES (138 KV & 69 KV)**

EU00513844
Revision: 4
Effective Date: 10/1/2018
Sheet 4 of 86

5.4 PPL EU BILLING METERING 50

5.5 OPERATING TRANSFORMERS..... 50

5.6 MICROPROCESSOR-BASED RELAYS, PROGRAMMABLE LOGIC CONTROLLERS (PLC), TRIPPING SOURCES, AND REMOTE ALARMS 50

5.7 RELAY TEST COMMISSIONING PROCEDURES..... 52

5.8 COMMISSIONING PROCEDURES FOR NON-RELAYED POC PROTECTION..... 53

SECTION 6 MAINTENANCE..... 54

SECTION 7 DRAWING REQUIREMENTS..... 56

7.1 DRAWINGS AND INFORMATION FOR REVIEW..... 56

7.2 CONTENTS OF DRAWINGS..... 56

7.3 DRAWING APPROVAL PROCEDURES 61

7.4 FINAL AS-BUILT DRAWINGS 61

SECTION 8 LIST OF APPLICABLE ANSI/IEEE STANDARDS..... 62

APPENDIX 63

1.0 GENERAL POINTS FOR CUSTOMER-OWNED GENERATION 63

2.0 DRAWINGS FOR REVIEW 65

3.0 TRANSFERS AT LESS THAN 600 VOLTS 65

4.0 TRANSFERS AT 12 kV (15 kV NOMINAL)..... 80



**TRANSMISSION PROTECTION & CONTROL
POINT OF CONTACT REQUIREMENTS FOR
CUSTOMER-OWNED FACILITIES (138 KV & 69 KV)**

EU00513844
Revision: 4
Effective Date: 10/1/2018
Sheet 5 of 86

FOREWORD

PPL Electric Utilities prepared the information contained in this document. This information represents minimum design requirements relative to safe and reliable operation for the PPL Electric Utilities system and personnel. However, this shall not relieve the customer from sole and complete responsibility for all aspects of design, installation, and operation of his facilities.

Neither PPL Electric Utilities nor any person acting on behalf of PPL Electric Utilities;

- (a) makes any warranty with respect to the use of information disclosed in this document or that such use may not infringe on privately owned rights; or
- (b) assume any liabilities with respect to the use of, or for damages resulting from the use of, any information disclosed in this document.



**TRANSMISSION PROTECTION & CONTROL
POINT OF CONTACT REQUIREMENTS FOR
CUSTOMER-OWNED FACILITIES (138 KV & 69 KV)**

EU00513844
Revision: 4
Effective Date: 10/1/2018
Sheet 6 of 86

SECTION 1 OVERVIEW OF INTERCONNECTING UTILITY AND CUSTOMER FACILITIES

1.1 INITIATING A REQUEST TO ADD OR MODIFY CUSTOMER CONNECTIONS

All projects to add or modify an existing business customer's connection to the PPL EU system should start with a call to the PPL Electric Utilities Business Accounts Department at telephone number **1-888-220-9991, menu option 4**, to contact a Business Accounts service representative, who will appropriately respond to your inquiry. Alternatively, you may initiate a contact to Business Accounts via the PPL EU website at: [Business Accounts Department](#) or email us at businessaccounts@pplweb.com.

1.2 POINT OF CONTACT - GENERAL

This document defines specific practices required for the interconnection of customer facilities to the utility system at 138 kV and 69 kV supply voltages. The point of interconnection for a customer facility will be defined by the term Point of Contact (POC), which defines the physical point where the customer's facilities connect to the PPL EU system. Associated with the POC are the protective relay and control functions required by the utility to provide the necessary isolation of customer facilities under fault conditions either in the customer facility or on the PPL EU system. These protective systems will be referred to as the POC protection or POC relays.

Point of Contact protection is required to protect PPL EU facilities (and other customers supplied from the same line) from faults in the customer's equipment. POC protection is not intended or specified to provide protection for the customer's equipment or facilities. The customer must provide additional protection devices to adequately protect his equipment; any protection of the customer's equipment that is provided by the POC protection is coincidental—it must not be relied upon for comprehensive protection of the customer's equipment. Accordingly, the current transformers, main protective relays, auxiliary relays, and tripping contacts used in the POC circuits are reserved exclusively for protection of the PPL EU system; totally separate facilities must be provided for the customer's protection. No additional relaying, metering or monitoring devices may be included in the current transformer (CT) circuit or potential transformer (PT) circuit designated for POC protection. Similarly, the fuse choices and relay settings are specified to provide the best possible protection for the PPL EU system for faults in the customer's equipment; these settings may not coordinate with the customer's low side protective devices or provide complete protection of the customer's equipment.

An additional disconnecting device, referred to as the PPL MOLBAB (motor-operated, load-break, air-break) switch, or more simply as the MOLBAB, shall be installed on the last PPL EU transmission structure before each 138 kV or 69 kV supply line crosses the customer's facility fence and connects to the customer's dead-end. This disconnecting device will typically consist of a MOLBAB (motor-operated load break air break) switch, although a circuit switcher could be required under some special situations. The type of

disconnecting device will be specified by PPL EU.

Specifications for several special types of customer connections are covered by other PPL EU documents or procedures, as follows:

- Customer installations from 12 kV supply lines are covered in two documents at the PPL EU website:
 - [PPL Electric Utilities Point of Contact Requirements for Distribution Voltage Customer-Owned Facilities 12 kV Supply \(EU00513845\)](#)
 - [REMSI \(Rules for Electric Meter and Service Installations\)](#)
- This document does not cover voltages at 230 kV or higher. Customers requiring service at 230 kV or higher voltages shall refer to the PPL EU Technical Standards as documented on the PJM website: www.pjm.com; specifically, the Substation Construction Standard 2-082, "PPL EU Requirements for Transmission Connected Facilities to be Owned and Operated by PPL EU". These protection schemes may require PJM approval and special permits. Customers desiring service at voltages of 230 kV and higher should contact the PPL EU Business Accounts Department at: [Business Accounts Department](#) for information and referrals to the proper groups and individuals to address their needs.
- Customers requiring service at 138 kV or 69 kV, with extremely large motors which could serve as energy storage devices and supply current back to the PPL EU system for supply line faults, must consult PPL EU for the proper POC protection. These installations with large motors may require reverse power or directional current protection as part of the POC protection package. Customers with facilities including large motors should contact the PPL EU Business Accounts Department at: [Business Accounts Department](#) for information and referrals to the proper groups and individuals to address their needs.
- If a customer is planning to operate a generator in parallel with PPL EU such as Independent Power Producers (IPP) or Distributed Generation (DG), additional inter-tie protection and metering will be required. The customer must contact PPL EU for the requirements of parallel operation of customer's generation as covered under the document at the PPL EU website: [Relay and Control Requirements for Parallel Operation of Generation \(138 kV & 69 kV\) \(EU00530561\)](#).

The various sections of this Customer POC Guidelines document address customer facilities with transformation at supply voltages from 69 kV to 138 kV with single or multiple utility lines of supply.

The following configurations are covered by this document.

1.2.1 Single Utility Supply Line

Single line supply is covered as follows:

- 69 kV supply line with 69 kV fused protection.
- 69 kV supply line and higher voltages with other than fused protection.

1.2.2 Multiple Utility Supply Lines

Multiple line supply is covered in two broad categories:

- Under normal operation the customer facility does not parallel utility supply lines, but allows for the transfer of customer load in a “break- before-make” manner for loss of a utility supply line.
- Under normal operation, the customer facility parallels the utility supply lines, at the customer’s load bus voltage (which can be 12 kV or lower).

PPL EU can help the customer determine the best facility configuration based on economics and electric service reliability.

Refer to Section 2 for a list of the customer’s responsibilities.

1.3 METERING OF ELECTRIC SERVICE

PPL EU normally meters and bills at voltages of 12 kV or below. For billing metering of electric service at 12 kV or lower voltages, please refer to the PPL EU document titled, [REMSI \(Rules for Electric Meter and Service Installations\)](#).

Distributed Generation installation will require metering facilities not discussed in REMSI. To obtain these requirements, please contact [Business Accounts Department](#).

1.4 DEFINITIONS

Overview

Please note that PPL EU uses the following defined terms for various utility and customer facilities’ configurations.

Type A An electrical facility that is supplied normally by a single utility line. Also considered as Type A is an electrical facility served by two supply lines, with one line carrying the entire substation load and the second line as standby.

Refer to the One Line Relay/Meter Diagram on page 31.

Type AA An electrical facility that is supplied by two utility supply lines which are not paralleled by the customer facility, but allows for the transfer and restoration of customer load in a “break-before-make” manner.

Refer to the One Line Relay/Meter Diagram on page 40.

Type B An electrical facility that is supplied normally by two utility lines paralleled on the customer’s load bus.



**TRANSMISSION PROTECTION & CONTROL
POINT OF CONTACT REQUIREMENTS FOR
CUSTOMER-OWNED FACILITIES (138 KV & 69 KV)**

EU00513844
Revision: 4
Effective Date: 10/1/2018
Sheet 9 of 86

Refer to the One Line Relay/Meter Diagram on page 50.

Alternate Source	A standby source which can be selected to supply customer load when the normal source is not available. The alternate source cannot be used simultaneously with the normal source.
BA	Business Accounts Services
CTs	Current Transformers
DG	Distributed Generation (customer-owned generation)
FID	Fault Interrupting Device (a circuit breaker, circuit switcher or fuse which is capable of interrupting fault current)
IPP	Independent Power Producers (customers with generation, operated with the purpose of selling power via the PPL EU transmission system and requiring a PJM contract)
KI	Kirk Key Interlock
PLC	Programmable Logic Controller
POC	Point of Contact
PPL EU	PPL Electric Utilities
PTs	Potential Transformers
REMSI	Rules for Electric Meter and Service Installations
TCM	Trip Circuit Monitor

1.5 POWER TRANSFORMER CONNECTIONS AND VECTOR DIAGRAMS

PPL EU System - 138 kV and Below

PPL EU employs a "C-B-A" phase sequence (rotation) at voltage levels of 230 kV and below.

PPL EU connects the high side of its delta-wye power transformers in the following manner in all divisions except the Lancaster Division.

C phase – H3 Bushing
B phase – H2 Bushing
A phase – H1 Bushing

For the Lancaster Division:

C phase – H1 Bushing
B phase – H2 Bushing



**TRANSMISSION PROTECTION & CONTROL
POINT OF CONTACT REQUIREMENTS FOR
CUSTOMER-OWNED FACILITIES (138 KV & 69 KV)**

EU00513844
Revision: 4
Effective Date: 10/1/2018
Sheet 10 of 86

A phase – H3 Bushing

For all PPL EU divisions except Lancaster, the transformer connections noted above and the standard phase relationships and transformer terminal designations for three-phase power transformers as outlined in IEEE Standard C57.12.00-2015 result in a non-standard phase displacement of the low side voltage leading the high side voltage by 30 degrees.

For Lancaster Division, the transformer connections noted above and the standard phase relationships and transformer terminal designations for three-phase power transformers as outlined in IEEE Standard C57.12.00-2015 result in a standard phase displacement of the low side voltage lagging the high side voltage by 30 degrees.

The diagrams on the following page illustrate the transformer connections and angular displacements noted in the discussion above.

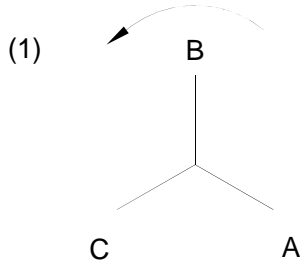

PPL EU 230KV AND
BELOW C-B-A
ROTATION

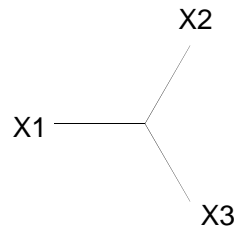
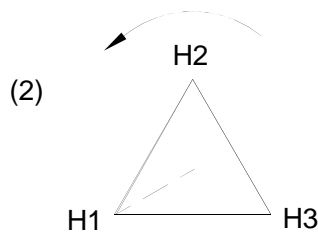

INDUSTRY STANDARD

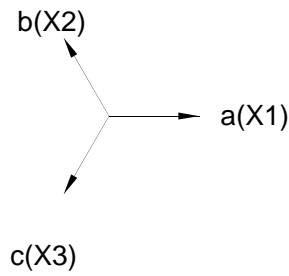
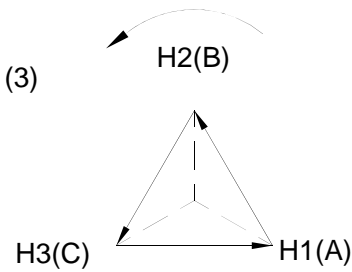

LOW VOLTAGE LEADS
HIGH VOLTAGE BY 30°
(SYSTEM, EXCEPT
LANCASTER).

HIGH VOLTAGE

LOW VOLTAGE

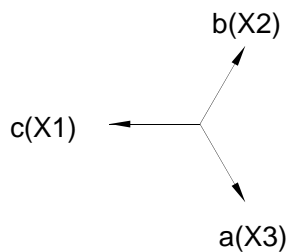
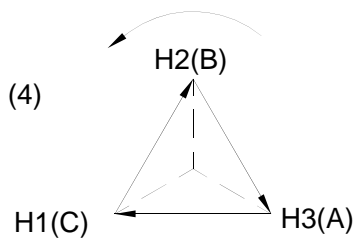

LOW VOLTAGE LAGS
HIGH VOLTAGE BY 30°
(LANCASTER).

HIGH VOLTAGE

LOW VOLTAGE



**TRANSMISSION PROTECTION & CONTROL
POINT OF CONTACT REQUIREMENTS FOR
CUSTOMER-OWNED FACILITIES (138 KV & 69 KV)**

EU00513844
Revision: 4
Effective Date: 10/1/2018
Sheet 12 of 86

1.6 BASIC INSULATION LEVELS AND CLEARANCES

Minimum insulation levels for service voltage (higher levels are customer's option):

69 kV system = 350 kV BIL
138 kV system = 550 kV BIL

Electrical clearances (phase-to-phase, phase-to-ground, elevation above grade/road, etc.) of bus conductor and equipment in a substation shall, at a minimum, be designed to the National Electrical Code (NEC) and National Electrical Safety Code (NESC) requirements, latest code revisions, for the BIL insulation levels chosen.

Minimum phase-to-phase (centerline) spacing of point-of-contact air switches and tie air switch (if installed).

<u>Nominal System Voltage (kV)</u>	<u>Basic Impulse Level (kV BIL)</u>	<u>Disconnecting Vertical Break (inch)</u>	<u>Switches Side Break (inch)</u>	<u>All Horn Gap Switches* (inch)</u>
69	350	60	72	84
138	550	84	108	120
138	650	96	120	144

*This category includes any switch having attachments which perform open-air arc extinction.

1.7 VOLTAGE LEVELS AND VARIATION

The primary voltage levels on the PPL EU system are as noted below:

<u>Nominal System Voltage (kV)</u>	<u>Typical Voltage Range at Point of Connection High - Low (kV)</u>
69	68 - 62
138	140 - 131

The anticipated operating voltage at a given location can be obtained by contacting the PPL EU representative.

1.8 CUSTOMER-OWNED TRANSFORMER SELECTION (nominal 138-12 kV and 69-12 kV)

Power transformer nominal voltage selections must be made in cooperation with PPL EU to ensure optimal operating performance of the customer-owned facilities. PPL EU will assist the customer or engineering consultant with selection of appropriate power transformer high-side and low-side voltages. (e.g. 67-13.2 kV for 69 kV service)

1.9 INSTALLATIONS INVOLVING 12 KV SUPPLY

For installations involving 12 kV supply lines, see the information in these PPL EU documents, which are on the PPL EU website:

- [PPL Electric Utilities Point of Contact Requirements for Distribution Voltage Customer-Owned Facilities 12 kV Supply \(EU00513845\)](#)
- [REMSI \(Rules for Electric Meter and Service Installations\)](#)

1.10 INSTALLATIONS INVOLVING 69 or 138 KV SUPPLY

For installations involving 69 or 138 kV supply lines, see Sections 3, 4 and 5 of this document.

1.11 INSTALLATIONS INVOLVING CUSTOMER-OWNED GENERATION

For installations involving customer-owned generation with break-before-make (also known as “open transition”) or make-before-break (“closed transition”) with parallel operation for 100 milliseconds or less (or up to 5 minutes with additional protection), see the Appendix-Requirements for Customer Emergency Standby Generation, at the end of this document.

If a customer is planning to parallel a generator with the PPL EU system continuously to sell power or for periods longer than 5 minutes when switching between sources, then additional inter-tie protection and metering will be required. The customer must contact PPL EU for the requirements as covered under the document at the PPL EU website: [Relay and Control Requirements for Parallel Operation of Generation \(138 kV & 69 kV\) \(EU00530561\)](#).

SECTION 2 CUSTOMER RESPONSIBILITIES

The list of Customer Responsibilities covered in the following pages provides the customer with a list of activities that must be completed before obtaining high-voltage service or if an existing customer is planning to change their facilities, equipment or load.

Obtaining the information listed below in a timely manner will aid PPL EU greatly in our efforts to coordinate the installation of POC protection equipment at the point of contact for high-voltage service.

69 KV or 138 KV SUPPLY – CUSTOMER RESPONSIBILITIES

<u>Description</u>	<u>Reference</u>
<input type="checkbox"/> Call PPL EU Business Accounts Department to initiate process	Telephone No. 1-888-220-9991, menu option 4
<input type="checkbox"/> Complete Application for Service	PPL EU Application for Electric Service
<input type="checkbox"/> Submit preliminary site drawings, including plan and elevation views, showing desired location and orientation of substation for PPL EU to provide design tensions for customer dead-end structure	
<input type="checkbox"/> Provide Letter of Intent prior to the start of PPL EU engineering	
<input type="checkbox"/> Submit customer proposed one-line diagram as described in the reference	Point of Contact Protection & Control Requirements (Section 5) and *REMSI
<input type="checkbox"/> If emergency backup generation is installed, provide a one line diagram showing connection of the PPL EU service to the generation equipment. Provide the manufacturer and model number of the transfer switch.	*REMSI Sketch 41 series
<input type="checkbox"/> Submit preliminary control drawings, transmission line dead-end, substation layout and specifications for PPL EU acceptance prior to ordering equipment	Point of Contact Protection & Control Requirements (Section 5)
<input type="checkbox"/> Submit CT/VT/meter location and switchgear drawings for acceptance	*REMSI Rules 3, 7, 8, 13, 18
<input type="checkbox"/> Complete transformer data sheet and submit transformer drawings for review prior to ordering (kVA, connection, taps, impedance, primary/secondary voltages)	Transformer Data Sheet and Physical & Electrical Design Requirements (Section 4)



**TRANSMISSION PROTECTION & CONTROL
POINT OF CONTACT REQUIREMENTS FOR
CUSTOMER-OWNED FACILITIES (138 KV & 69 KV)**

EU00513844

Revision: 4

Effective Date: 10/1/2018

Sheet 15 of 86

- Supply slide bar lock on substation gate and disconnecting device
- Submit switch, interlock schematic & details Physical & Electrical Design Requirements (Section 4)
- Return signed Electric Service Contract prior to the start of PPL EU construction
- Provide payment of costs to PPL EU for 69 kV and/or 138 kV service
- Execute Right-of-Way agreement for transmission line easement
- Submit final substation site location and orientation, horizontal and vertical survey control points, and phase orientation of transformer Physical & Electrical Design Requirements (Section 4)
- Submit final control drawings incorporating required PPL EU changes for point-of-contact protection **prior** to connection to PPL EU system Point of Contact Protection & Control Requirements (Section 5)
- Provide power transformer certified test reports for compensated metering (%) exciting current, % impedance, core loss, full load copper loss Physical & Electrical Design Requirements (Section 4)
- Provide Bill of Material (major electrical equipment only) Physical & Electrical Design Requirements (Section 4)
- Inform PPL EU when point-of-contact relays are available for testing/setting
- Call PPL EU when ready for PPL EU billing metering (separate from POC equipment) CT/VT delivery
- Install PPL EU billing metering CTs and VTs per PPL EU specifications *REMSI & Supervisor Metering Services
- Provide substation ground grid resistance test report per IEEE Standard 80 Physical & Electrical Design Requirements (Section 4)
- Provide insulation test results for all 69/138 kV equipment up to and including point-of-contact protection device
- Complete inspection requirements - independent electrical final one-line diagram *REMSI Rule 19
- Provide as-built drawings for PPL EU file, including final one-line diagram (if applicable for non-fused POC)

*REMSI (Rules for Electric Metering & Service Installation)

LOCATION CODE: **R073**

SECTION 3 PPL TRANSMISSION LINE AND SUBSTATION REQUIREMENTS

3.1 The customer must have PPL EU review and concurrence of their substation design details before placing orders for any 69 kV or 138 kV substation materials. PPL EU will determine the required structure types & framing needed to support the incoming transmission line based on the latest PPL EU standards & criterion at the time of request. This could be either direct embedded or concrete foundation steel poles.

3.2 The customer is responsible to provide an attachment for each conductor and overhead ground wire that is terminated at the customer owned substation. This is typically a steel vang with a 1.5" diameter hole. These attachments must be properly dimensioned and designed to accept typical transmission line hardware such as a tower fitting (Ohio Brass #82857 or equivalent) and the ultimate design load of the incoming wire tension. PPL EU will supply all of the terminating hardware from the attachment point out to the transmission line.

The height of the customer sub dead-end attachment points must accommodate 30' ground clearance of the incoming conductor span at maximum sag conditions. The customer must also provide an air switch or bus connector pad at each conductor position to accept a cable-to-flat terminal connector (NEMA spaced holes in the pad) that is provided and installed by PPL Electric Utilities at the each conductor termination. Typically a strain clamp with a tail and cable to flat connector is provided by PPL EU or in some cases a compression dead-end with the NEMA pad included.

Where the overhead ground wire terminates at the customer's dead-end, the customer must provide a place for PPL EU to bond the wire to a structural member that is electrically bonded by the customer to the substation grounding system. A ½"-20 stainless steel nut welded to the structure is the typical bonding connection type.

3.3 PPL EU prefers a substation orientation that has the last PPL EU transmission line structure turning a 75 degree to 105 degree angle off the main line and then straight into the customer's dead-end structure. No transmission conductor may turn more than 15 degrees vertically or horizontally off the substation dead-end, as determined by PPL EU. The last transmission structure should be a minimum of 75 feet and a maximum of 150 feet from the customer dead-end.

Such an orientation allows PPL EU the option to guy off the high tension of the main line at the last transmission structure, lower the incoming line tension to the customer substation, and provide adequate phase-to-phase and phase-to-ground conductor clearances. If such an orientation is not available and structure guying is not applicable at the last transmission structure, PPL EU will provide a self-supporting structure with concrete foundation to accommodate the above noted requirements.

3.4 The customer's substation dead-end structure must sustain a minimum of 6,250 pounds working tension per terminating conductor and overhead ground wire. A design safety factor of 1.25 is included in this maximum tension value. PPL EU designs its transmission facilities to meet:

(1) NESC heavy loading with NESC safety factors applied,

(2) 1.5" Radial Ice, No Wind, 32°F on the conductors and structures, with a 1.0 safety

LOCATION CODE: **R073**



**TRANSMISSION PROTECTION & CONTROL
POINT OF CONTACT REQUIREMENTS FOR
CUSTOMER-OWNED FACILITIES (138 KV & 69 KV)**

EU00513844

Revision: 4

Effective Date: 10/1/2018

Sheet 17 of 86

factor

- (3) 2007 NESC loading condition 250D of 1-inch radial ice with 4 pounds per square foot wind load applied to all iced conductors and structures, increased by a 1.25 safety factor.

PPL EU does not recommend the use of any wood structures for substations.

- 3.5 As part of the coordination of the project construction details, PPL EU will provide the customer with wire sizes of the incoming conductors and overhead ground wire or OPGW if required. Any deviation from the conditions noted above may result in additional requirements imposed by PPL EU on the customer to accommodate the incoming transmission conductors. The customer must provide PPL EU their conductor phase arrangement for the terminating transmission line as part of the general orientation layout.
- 3.6 PPL EU may provide combination insulator/high-voltage lightning arrester assemblies (if required and if the physical clearances will accommodate the lightning arrester operation) to terminate the incoming transmission line power conductors to the customer's dead end structure. If the combination assembly cannot be accommodated, then a glass insulator assembly will be provided. Even if PPL EU supplies the combination insulator/high-voltage lightning arrester assembly, the customer is still responsible to install lightning arrestors per Section 4.6.4, to provide protection for the customer's equipment.
- The customer must provide a place for PPL EU to bond the ground end of the insulator/LA assemblies to a structure member that is electrically bonded by the customer to the substation grounding system.
- 3.7 Phase-to-phase spacing on the customer's dead end structure shall match PPL EU specifications for the corresponding voltage class of substation as contained in Section 1, Subsection 6 of this document.
- 3.8 PPL EU reserves the right to require further design requirements or substation orientation changes to best accommodate the transmission termination if unique features or conditions exist in the customer's proposed facility.
- 3.9 PPL EU will provide an additional sectionalizing device, located on the last PPL EU pole outside the customer's substation, before the 138 kV or 69 kV supply lines cross the customer's facility fence and connects to the customer's dead-end structure. This device will typically consist of a 69 kV or 138 kV MOLBAB (motor-operated, load-break, air-break) switch and will be provided with a control cabinet including a battery, control switch, indicating lights, fuses, auxiliary contacts, a cellular SCADA device to allow remote operation by PPL EU and possibly a fault detector.

In some circumstances, a circuit switcher may be required; the type of disconnecting device and control cabinet design will be specified by PPL EU for each case. The purpose of this additional disconnecting device is to provide a means to sectionalize the supply line by PPL EU personnel, either remotely or manually. This device will be accessible by PPL EU personnel without requiring admittance or accompaniment by the customer's personnel. Conversely, the customer's personnel will not be allowed access to this device or its controls.

LOCATION CODE: **R073**

SECTION 4 SUBSTATION PHYSICAL ELECTRICAL AND EQUIPMENT REQUIREMENTS

4.1 SUBSTATION ORIENTATION AND PPL EU TRANSMISSION LINE

The location and orientation of the customer-owned substation must be coordinated with the PPL EU Transmission Line requirements of Section 3.

4.2 SUBSTATION LINE DEAD-END STRUCTURE

The customer shall provide a suitable free-standing or guyed structure to terminate PPL EU 138 kV or 69 kV line(s). The structure can be steel or aluminum (wood is not recommended) and shall be designed to accommodate the tension and clearance requirements of the transmission line(s) as noted in Section 3 (above).

Parameters for terminating the transmission line must be obtained from Transmission Engineering before the customer commits to a design for the dead-end structure.

4.3 GROUNDING REQUIREMENTS

The customer's outdoor substation facilities must have an adequate grounding system so arranged to prevent hazardous step and touch potentials. The grounding system shall be designed in accordance with IEEE Standard 80, "Guide for Safety in AC Substation Grounding," latest revision, and include the following:

- 4.3.1 Substation shall have a perimeter ground ring approximately 3 feet outside the fence line.
- 4.3.2 All gate entrances, man and vehicular, shall have their stationary posts bonded to each other and to the swing panels. Stationary post bonding by connections to the perimeter ground ring is acceptable.
- 4.3.3 The perimeter ground ring shall be designed to accommodate the swing of the entrance gate.
- 4.3.4 All air switch operating mechanisms shall be bonded to the substation structure by a suitable flexible braid connection from the operating pipe (near the operating mechanism) to the structure. A connection shall be made from the structure (near the operating mechanism) to the ground grid.
- 4.3.5 Each mechanism shall also have an ABOVE-GRADE steel platform/grating bonded to both the operating pipe and the ground grid.
- 4.3.6 Substation yard surfacing (4-inch minimum layer of crushed stone or macadam) shall extend 5 feet beyond the substation fence line along all sides.

4.4 GROUND GRID TESTING

For customer facilities supplied at 138 kV or 69 kV, the customer shall have the substation grounding system tested for "resistance to remote earth" prior to making connections to the PPL EU lines and energizing the facility. The customer is responsible for arranging the test(s) and costs associated with such work. The tests shall be made in accordance with the "Fall of Potential" method as outlined in IEEE Standard 81, "Guide for Measuring Earth Resistivity, Ground Impedance, and Earth Surface Potentials of a Ground System," latest revision.

All tests shall be conducted before any PPL EU shield wires, counterpoises and/or system neutrals are connected to the facility. If any external neutrals are connected before conducting ground testing, the results will yield false, lower value readings. Neutral(s) of any temporary construction power services must be properly isolated from the substation grounding system before tests are made. The test circuit configuration shall be so arranged that no "sneak circuits" exist through the measurements.

The reference "current probe" (C2) must be driven at a point beyond the "extent" of the ground system under test to obtain meaningful results.

All ground resistance test results must be submitted to PPL EU for approval and must include:

- 4.4.1 Geometry of the test circuit showing relative positions/directions and distances between test and reference electrodes. An accurate sketch or field-marked location plan drawing is acceptable.
- 4.4.2 Actual resistance measurements at several reference points including the "theoretical 62% point." Measurements shall be submitted as tabled values and graphically to illustrate the "plateau" and inflection points in the resistance curve.

PPL EU requires the effective resistance to remote earth of the customer's substation ground grid to be **five (5) ohms** or less.

4.5 POINT OF CONTACT SWITCHING DIAGRAMS AND NOTES

4.5.1 Point-of-Contact Switching Requirements

The customer-owned substation can be configured with either a single line or a two line supply. Two line supply situations may require additional cost to the customer.

- a) Single line supply without alternate source.
- b) Two line supply, with one normal and one alternate source.
- c) Two line supply with load split between the two sources.

4.5.2 Single Line Supply – No Alternate Source

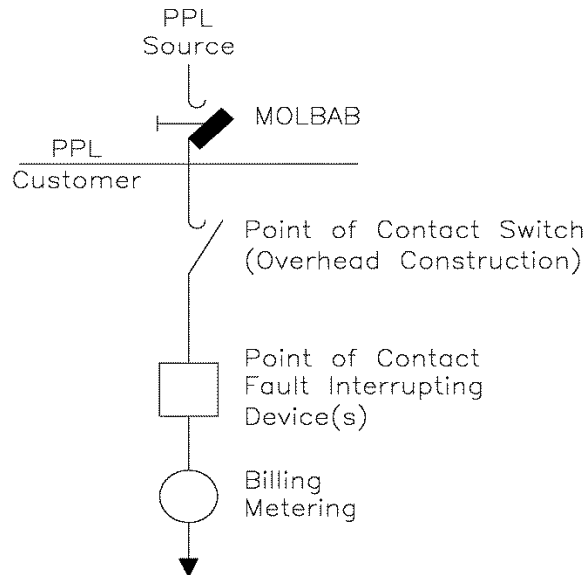

All switches and devices are normally closed unless otherwise specified.

The point-of-contact switch is required for overhead, open-air construction to serve as a visible break at the point where the customer's facilities connect to the PPL EU system. This switch must:

- a) Be a three-phase, gang-operated air break switch (manually or motor operated). Single pole disconnects are not acceptable.
- b) At 69 kV or 138 kV, the switch must have the capability to interrupt bus charging and transformer magnetizing currents (non-load break operation); full load break capability is customer's option.
- c) Be capable of being secured and padlocked in the open position.

Reference Subsections 4.6.2 and 4.6.3 for additional information on switches and interrupting devices.

4.5.3 Two Line Supply – With Normal and Alternate Source

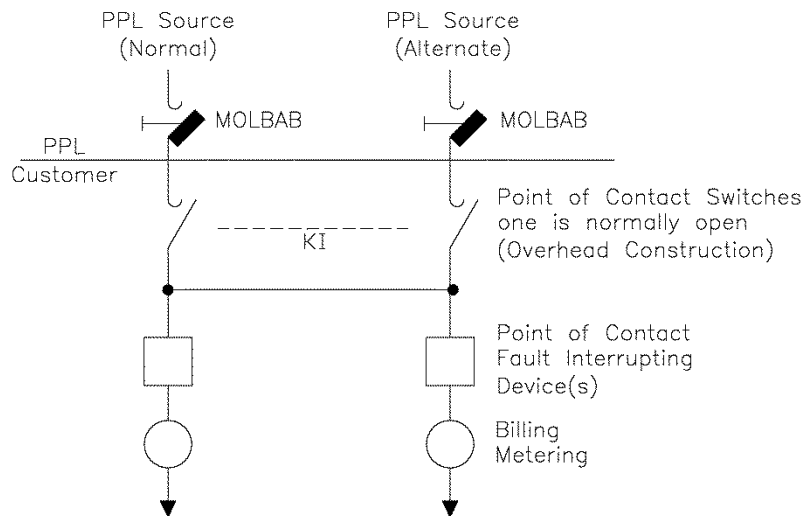

One switch and device are normally closed (the other switch is normally open) unless otherwise specified.

The point-of-contact switches are required for overhead, open-air construction to serve as a visible break at the point where the customer's facilities connect to the PPL EU system. These switches must:

- a) Be three-phase, gang-operated air break switches (manually or motor operated). Single pole disconnect switches are not acceptable.
- b) At 69 kV or 138 kV, the switch must have the capability to interrupt bus charging and transformer magnetizing currents (non-load break operation); full load break capability is customer's option.
- c) Have the capability to interrupt parallel loop current flow between the two PPL EU sources when the customer's load is transferred between sources without a service interruption (by authority of PPL EU System Operator).
- d) Be mechanically interlocked (electrically if motor operated) to prevent unauthorized paralleling of the PPL EU source lines. The interlock system (KI) shall contain an interlock "cheater" key (tamperproof interlock bypass switch if electrical) for controlled switching by PPL EU personnel only.
- e) Be capable of being secured and padlocked in the open position.

Reference Subsections 4.6.2 and 4.6.3 for additional information on switches and interrupting devices.

4.5.4 Two Line Supply – Load Split Between Two Sources

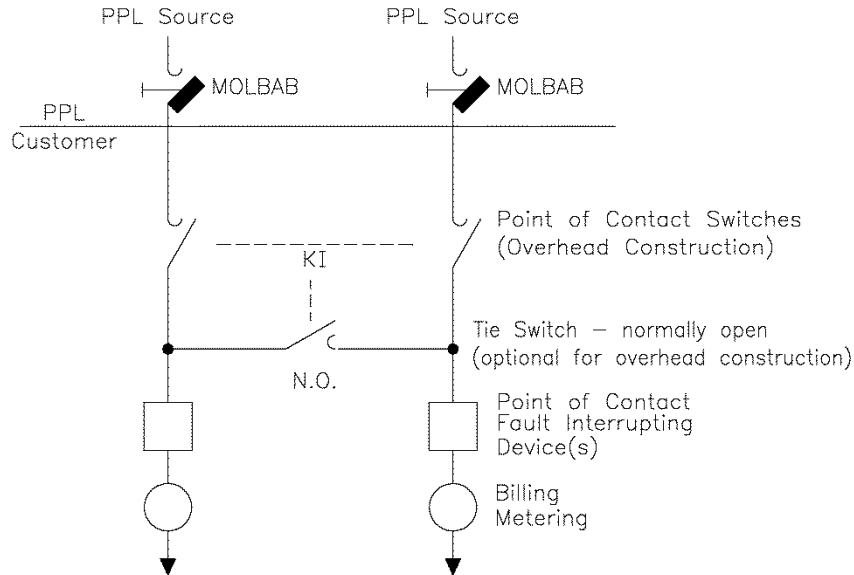

All switches and devices are normally closed unless otherwise specified.

The point-of-contact switches are required for overhead, open-air construction to serve as a visible break at the point where the customer's facilities connect to the PPL EU system. These switches must:

- Be three-phase, gang-operated air break switches (manually or motor-operated). Single pole disconnect switches are not acceptable.
- At 69 kV or 138 kV, the switch must have the capability to interrupt bus charging and transformer magnetizing currents (non-load break operation); full load break capability is customer's option.
- Have the capability to interrupt parallel loop current flow between the two PPL EU sources when the customer's load is transferred between sources without a service interruption (by authority of the PPL EU System Operator).
- Be mechanically interlocked (electrically if motor operated) to prevent unauthorized paralleling of the PPL EU source lines. The interlock system (KI) shall contain an interlock "cheater" key (tamperproof interlock bypass switch if electrical) for controlled switching by PPL EU personnel only.
- Be capable of being secured and padlocked in the open position.

A tie switch must:

- Be a three-phase, gang-operated air break switch similar to the

point-of-contact switches.

- b) Be interlocked with the point-of-contact switches.
- c) Have parallel loop current interrupting capability (necessary only if total plant load cannot be supplied by one power transformer on a continuous basis).

Reference Subsections 4.6.2 and 4.6.3 for additional information on switches and interrupting devices.

4.6 EQUIPMENT AND MATERIAL

4.6.1 Power Transformers

The customer's 69 kV or 138 kV power transformers (nominal high voltage values) must have DELTA-connected primary windings. This requirement is for customers with load or load with emergency standby generation (and break-before-make switching). If the customer has IPP or Distributed Generation (make-before-make switching), see the document titled "Relay and Control Requirements for Parallel Operation of Generation" found at website: [Relay and Control Requirements for Parallel Operation of Generation \(138 kV & 69 kV\)](#) .

Connection arrangement of the secondary windings is customer's option.

The voltage taps should accommodate the voltage criteria discussed in Section 1.7. The PPL EU representative shall be contacted to provide transformer tap recommendations prior to purchase and a desired tap setting at the specific location given the customer's load characteristics. (For example: PPL EU normally buys transformers for 69 kV use specified as 67-13.2 kV, with 2 2-1/2 % taps above and below the transformer high voltage midpoint of 67 kV.)

It is important for the customer to contact PPL EU for the transformer voltages, tap recommendations and desired tap setting **prior to the customer placing the transformer order.**

4.6.2 Point-of-Contact Circuit Isolation Devices - Switches and Interrupter Accessories

The following devices provide the physical means to disconnect, and provide a visible break, the customer-owned substation from the PPL EU utility system:

Air Switches – Gang-Operated

Air switch; 69 kV, 115 kV or 138 kV; three-pole, gang-operated, with horn gap; manual swing handle, worm gear drive or motor-operated mechanism.

Switch Interrupter Accessories

Interrupter accessories shall be installed on the point-of-contact switches as appropriate for the installation. These include, but are not limited to:

- Interrupter attachment (with whip interrupter) loop sectionalizing, line (bus) de-energizing, and transformer magnetizing current switching applications.
- Interrupter attachment (without whip interrupter) for loop sectionalizing (parallel switching) applications.

4.6.3 Point-of-Contact Fault Interrupting Devices (FID)

The following devices are approved for primary protection in customer-owned facilities:

Fuse Switch

Type SMD-2B, single pole, disconnecting type, 69 kV, 350 kV BIL, 300 amperes maximum continuous rating, 2,000 MVA interrupting rating. Approved Supplier: S&C.

Fuse unit, SMD-2B, 69 kV, 2,000 MVA interrupting capacity. (The ampere size and fuse characteristics will be determined by PPL EU.)

Circuit Switcher

69 kV, 115 kV or 138 kV, three pole, 1,200 ampere continuous and 64 kA momentary ratings, 20 kA primary and 4 kA inherent-secondary interrupting ratings.

Power Circuit Breaker

69 kV or 138 kV, oil, vacuum, or SF6 insulating medium, single or three-tank style. Interrupting rating to be determined based on PPL EU criteria for the particular proposed installation. Please contact PPL EU for detailed information.

4.6.4 Surge Arrester

Surge arresters must be connected to the LOAD side of the point-of-contact interrupting device. Location and quantity are to be determined by customer's engineering representative. Other locations must be reviewed with PPL EU Engineering for concurrence.

PPL EU strongly discourages connecting surge arrestors to the line side of the POC interrupting device. However, if conditions require this type of connection, the customer must use a self-disconnecting type of arrester.

PPL EU 69 kV and 138 kV systems may operate temporarily as an ungrounded system for up to 2 seconds during abnormal system conditions. The maximum 60-hertz voltage for determining the minimum arrester rating occurs during a temporary

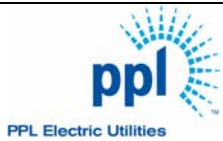

**TRANSMISSION PROTECTION & CONTROL
POINT OF CONTACT REQUIREMENTS FOR
CUSTOMER-OWNED FACILITIES (138 KV & 69 KV)**

EU00513844
Revision: 4
Effective Date: 10/1/2018
Sheet 25 of 86

ungrounded operation with concurrent single line-to-ground fault. Due to this condition, the recommended arrester ratings are (ZnO design):

69 kV Service - Intermediate Class and Station Class 72 kV (57 kV MCOV)

138 kV Service - Intermediate Class and Station Class 132 kV (104 kV MCOV)

(MCOV refers to the maximum continuous operating voltage.)

Note that PPL EU transmission lines may be terminated with a surge arrester, as discussed in Section 3.6.

4.6.5 Fault Currents

PPL EU 138-12 kV and 69-12 kV substations are designed to withstand fault currents of 20,000 amps. PPL EU recommends that customer switchgear and equipment be designed to handle this amount of fault current as a minimum. For actual fault duties at the customer's supply location, please contact PPL EU.

If the customer elects to design his equipment to meet a lower maximum fault current than the 20,000 amps recommended above, he must at least meet the calculated fault duties supplied by PPL EU for his location, plus a suitable margin. Future system changes to the supply system may increase the fault duties at the customer's location and any upgrades required to meet these increased fault duties will be at the customer's expense.

SECTION 5 PROTECTION AND CONTROL REQUIREMENTS

5.1 SINGLE LINE SUPPLY SUBSTATION – NO ALTERNATE SOURCE (TYPE A) (See diagram on page 31)

Substation Configuration and Operating Philosophy

The Type A configuration normally provides service to the customer via a single line of supply. Supply can be provided at voltages of 138 kV and below.

For higher reliability, additional options are available at customer expense, upon consultation with PPL EU.

5.1.1 Configuration

At 69 kV and 138 kV supply voltages, a power transformer is typically installed on the utility line of supply.

Fault interrupting devices (FID) such as fuses or circuit breakers or equivalent are installed on the power transformer high side. A second FID, typically a circuit breaker, is installed between each transformer low side and the customer operating bus.

5.1.2 Utility Supply Line Faults

Supply line faults are cleared remotely by the utility. When this action isolates the fault, the customer load is interrupted. (For customer substations with two independent supply lines, the load can be transferred manually to the alternate supply line.)

5.1.3 Power Transformer Faults

If a circuit breaker or other relay-operated device is the FID, a faulted power transformer will be isolated on the high voltage and optionally on the low voltage sides by the operation of protective high side over-current relays.

At customer substations where a high side transformer fuse is the FID, a faulted transformer is isolated by blown fuses. This action would isolate the customer operating bus from the fault and the entire customer load is interrupted.

5.1.4 Customer Operating Bus

At customer substations with 69kV or 138 kV service, the operating bus is not considered part of the POC relaying. The customer may provide specific protection for the operating bus at his discretion.

5.1.5 Customer Equipment Protection

Additional protective relaying can be applied as required to protect customer equipment including the operating bus and transformers. These customer-specified relays can initiate a trip of the customer's high side and/or low side FID but are not considered POC relaying. These additional customer's relays must be connected to separate CTs; they may not be connected to CTs used for POC protection relays.

PPL EU may comment on additional customer relaying, but these relay settings will not be specified, nor will the settings be applied by the utility.

If master trip relays are used to open the POC FID, separate master trip relays will be applied for the POC protection and the customer's additional protection; these two separate relay packages will not share a common master trip relay.

5.1.6 Normal Operation

Under normal operating conditions, the transformer POC interrupting device is closed and the transformer is energized and carrying load.

At customer substations supplied with two independent lines, either line can be the normal source; the FID associated with the normal supply line is normally closed, and the FID associated with the alternate supply line is normally open.

5.1.7 Automatic Reclosing

Automatic reclosing for single line supply substations is not permitted on the utility supply side FID.

POC Protection and Control Requirements

The following are the POC protection requirements for single line supply (Type A) substations:

5.1.8 Current Transformers

The customer's source FID shall be equipped with three multi-ratio current transformers (one per phase) for supply to the POC relays specified under the section titled Protective Relays. These current transformers shall be located on the outer-most position of the PPL EU supply line side of the FID bushings. All tap connections of the multi-ratio CTs must be wired out to terminal blocks and be accessible for future CT tap changes.

The POC current transformers must have a relaying accuracy class of C200 or better and be set on a tap such that the maximum available short circuit current does not produce saturation. The customer shall provide CT saturation study results to PPL EU.

The POC CTs must have a voltage rating equal to the FID that they are mounted on or are associated with, and must meet the BIL insulation ratings as specified in Section 1.6.

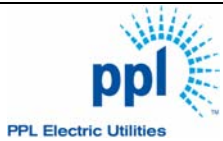

**TRANSMISSION PROTECTION & CONTROL
POINT OF CONTACT REQUIREMENTS FOR
CUSTOMER-OWNED FACILITIES (138 KV & 69 KV)**

EU00513844
Revision: 4
Effective Date: 10/1/2018
Sheet 28 of 86

These current transformers shall not be used as supply to the billing metering equipment, nor any other customer protection or monitoring functions. If additional protection or monitoring functions are desired for the customer's use, additional current transformers shall be supplied suitable for the customer's applications. Current transformers for the customer's non-POC use will be located on the inside of the CTs assigned for POC protection; in other words, the PPL EU POC CTs must be located in the outer-most position on the PPL EU supply line side of the POC FID bushings.

PPL EU will review current transformer tap settings proposed by the customer or, if requested, will specify the current transformer tap settings. PPL EU will supply fault current data at the point of the customer's connection to facilitate the proper sizing of the current transformers.

5.1.9 Protection for Utility Supply Line Faults

Supply line faults are cleared remotely by the utility. This action isolates the fault and the customer load is interrupted.

5.1.10 Protection for Power Transformer Faults

A. Transformer Fuses

At customer's substations with 69 kV service where fuses are installed, the customer shall provide 69 kV fuses which will be S&C Company type SMD-2B (SMD-3C units can sometimes be used if a larger interrupting rating is required—but the customer must discuss with PPL EU before changing from the standard SMD-2B). The fuse interrupting rating, link size and characteristics must be approved by PPL EU.

The 69 kV POC fuses provide clearing for faults on the customer's equipment.

B. Over-current Relays

Three phase (inverse) and one ground (very inverse) time and instantaneous over-current relays connected to current transformers on the PPL EU side of each 69 kV or 138 kV FID are required to detect faults in the transformer. This relaying must trip the utility side POC FID.

PPL EU will approve the relay ranges and settings for these POC relays. The instantaneous attachments of either or both of the phase and ground relays may be blocked from operation by PPL EU.

See the table of acceptable relays for POC protection at website: [Accepted Customer Point of Contact and Generator Intertie Protective Devices](#) for a list of acceptable POC relays. If a relay is not included in this list, it is not acceptable for POC duty.

5.1.11 POC Control Requirements

A. Control

- The FIDs (other than fuses) shall be equipped with hard-wired control switches for manual operation.
- POC protective devices must be hard-wired to trip the POC FID. POC relay trip contacts will not trip the POC FID via any type of intermediate microprocessor.
- Automatic reclosing of the POC FID is not permitted.

B. Indication

- The closed position of the FID shall be monitored with a red indicating light.
- The open position of the FID shall be monitored with a green indicating light.
- The FID trip coil shall be monitored either by a yellow indicating light or by the red indicating light in series with the FID trip coil and a FID auxiliary switch. A trip circuit monitor (TCM) is also acceptable. If the FID uses a capacitor trip device, the FID trip coil must be monitored by a yellow light in series with a pushbutton. This will allow a manual test of the FID trip coil continuity without placing a constant current drain on the capacitor charge.
- The trip coils of master trip relays shall be monitored with yellow indicating lights.
- Power to control circuits for POC relaying, master trip relay circuits and the FID control circuit shall be supplied via separate fuses. Each fuse shall be monitored for blown fuse or open circuit conditions with a yellow indicating light or annunciator drop.
- Annunciator alarms will be indicated or displayed in a location which is normally manned, so that any change of annunciator status is promptly noticed.

C. Test Facilities

POC relays shall be provided with isolation facilities so that all current and potential (if provided) inputs and trip contacts are wired through test points. If not provided by the manufacturer in the form of a draw-out relay case, additional test switches such as the ABB FT1 (or equivalent) must be provided by the customer.

D. POC Commissioning

For the initial commissioning of a customer's facility, the POC relays will be

LOCATION CODE: **R073**



**TRANSMISSION PROTECTION & CONTROL
POINT OF CONTACT REQUIREMENTS FOR
CUSTOMER-OWNED FACILITIES (138 KV & 69 KV)**

EU00513844
Revision: 4
Effective Date: 10/1/2018
Sheet 30 of 86

set and tested by PPL EU Relay Test personnel; PPL EU will also test the CTs (and PTs, if required) which supply the POC relays. Testing will include a full functional test, including tripping of the POC FID device.

5.1.12 Customer's Protection Schemes

The customer may supply protective relays in addition to the required POC relays, at his discretion. These additional relays will be supplied from CTs and PTs separate from the ones used to supply the POC relays. These additional relays will be set at the customer's discretion; if the settings are provided to PPL EU, we will try to set the POC relays to coordinate with the customer's relays, but cannot guarantee optimum coordination.

CUSTOMER TYPE "A"

69-12KV OR 138-12KV SUBSTATION

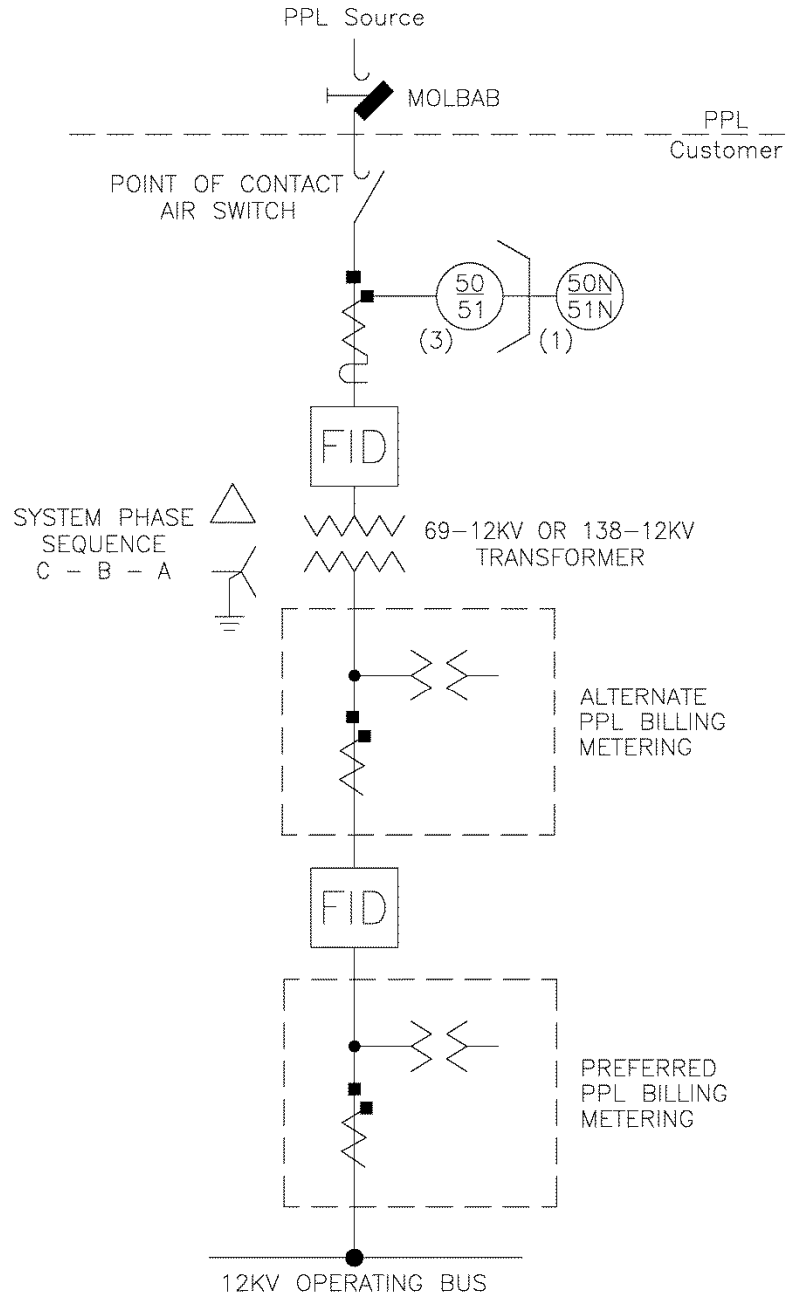

NOTE: At 69kV only, a fuse can be substituted for POC protection instead of the relays and FID.

ONE LINE RELAY/METER

LOCATION CODE: **R073**

5.2 TWO LINE SUPPLY SUBSTATION - OPEN TIE BETWEEN SOURCES (TYPE AA) (See diagram on page 40)

Substation Configuration and Operating Philosophy

The two-line supply (type AA) configuration provides service to the customer via two independent lines of supply. During normal operation as discussed below, the supply lines are not paralleled via the customer facility operating bus. Both supply lines are normal sources. Low side FIDs are normally closed, while the bus sectionalizing FID is normally open. Supply can be provided at voltages of 138 kV and below.

On loss of either source, the low side FID associated with the lost source is tripped and the bus sectionalizing FID is closed. Thus, the customer can feed his entire load from one source. Automatic or manual schemes will return the system to normal operation (via break before make switching) upon return of the normal source.

5.2.1 Configuration

At 69 kV and 138 kV supply voltages, a power transformer is typically installed on each utility line of supply.

FIDs such as fuses or circuit breakers or equivalent are installed on the power transformer high side. FIDs or the equivalent are installed between each power transformer low side and the customer operating bus.

The operating bus is sectionalized with a FID other than a fuse to allow load transfer on loss of a supply line or power transformer.

5.2.2 Normal Operation

Under normal operating conditions, the bus sectionalizing FID is open, both transformer low side fault-interrupting devices are closed, and both power transformers are energized and carrying load.

5.2.3 Operation Under Fault Conditions

A. Utility Supply Line Faults

Since the supply lines are not paralleled through the customer's equipment, supply line faults are cleared remotely by the utility. This action isolates the fault, and the corresponding customer load is interrupted briefly until the bus sectionalizing FID closes to supply the interrupted customer load from the alternative line.

B. Power Transformer Faults

At customer substations where a high side fuse is the point of contact protection, a faulted transformer is isolated by blown fuses.

If a circuit breaker or other relay-supervised device is the FID, then a faulted power transformer will be isolated on the high and low voltage sides by the operation of protective high side over-current relays.

Either of the above actions would isolate the faulted power transformer and the customer operating bus from the fault. The entire customer's load is then supplied by the remaining utility line.

5.2.4 Customer Operating Bus

Each customer operating bus section is typically protected by summation over-current or bus differential relaying; this relaying trips and blocks closing of the customer's transformer FIDs.

Although not part of the point of contact protection, these protection schemes will be reviewed by PPL EU since operation of these relays blocks automatic load transfer and closing of the 12 kV FIDs.

5.2.5 Other Customer Protective Relays

Additional protective relaying can be applied as required to protect customer equipment including the operating bus and transformers. These customer-specified relays can initiate a trip of the customer's low side FID, but are not considered POC relaying. These additional customer relays must be connected to separate CTs; they may not be connected to the CTs used for POC protective relays.

PPL EU may comment on this additional customer relaying, but relay settings are neither specified nor applied by the utility.

If master trip relays are used to open the POC FID, separate master trip relays will be applied for the POC protection and the customer's additional protection; these two separate relay packages will not share a common master trip relay.

5.2.6 Automatic Reclosing

Single shot automatic reclosing can be applied to the transformer low side FIDs. Initiating an automatic reclose, if provided, must only occur after supply line faults. Automatic reclosing must be blocked after transformer and operating bus faults.

The control logic associated with the transformer low side FIDs will be reviewed by the utility.

Protection and Control Requirements

The following are the POC relaying requirements for the two-line supply (Type AA) substation:

5.2.7 Current Transformers

The customer's source FID shall be equipped with three multi-ratio current transformers (one per phase) for supply to the POC relays specified under the section titled Protective Relays. These current transformers shall be located on the outer-most position of the PPL EU supply line side of the FID bushings. All tap connections of the multi-ratio CTs must be wired out to terminal blocks and be accessible for future CT tap changes.

The POC current transformers must have a relaying accuracy class of C200 or better and be set on a tap such that the maximum available short circuit current does not produce saturation. The customer shall provide CT saturation study results to PPL EU.

The POC CTs must have a voltage rating equal to the FID that they are mounted on or are associated with, and must meet the BIL insulation ratings as specified in Section 1.6.

These current transformers shall not be used as supply to the billing metering equipment, nor any other customer protection or monitoring functions. If additional protection or monitoring functions are desired for the customer's use, additional current transformers shall be supplied suitable for the customer's applications. Current transformers for the customer's non-POC use will be located on the inside of the CTs assigned for POC protection; in other words, the PPL EU POC CTs must be located in the outer-most position on the PPL EU supply line side of the POC FID bushings.

PPL EU will review current transformer tap settings proposed by the customer or, if requested, will specify the current transformer tap settings. PPL EU will supply fault current data at the point of the customer's connection to facilitate the proper sizing of the current transformers.

5.2.8 Potential Transformers

The customers must have three single phase, wye-connected, relaying class accuracy potential transformers connected on the load side of each power transformer.

These potential transformers must be able to support the connected relay burden during normal operation and system fault conditions. These potential transformers shall not be used as supply to the billing metering equipment, station service loads, nor any other customer protection or monitoring functions. If additional protection or monitoring functions are desired for the customer's use, the potential transformers must be supplied with dual secondary windings—one secondary winding must be reserved for PPL EU point of contact protection functions.

5.2.9 Utility Supply Line Fault Protection

Since the supply lines are not paralleled through the customer's equipment, supply line faults are cleared remotely by the utility. This action isolates the fault and the entire customer load is then supplied by the remaining supply line after the

customer's operating bus sectionalizing FID closes.

5.2.10 Power Transformer Fault Protection

A. Transformer Fuses

At customer's substations with 69 kV service where fuses are installed, the customer shall provide 69 kV fuses which will be S&C Company type SMD-2B (SMD-3C units can sometimes be used if a larger interrupting rating is required—but the customer must discuss with PPL EU before changing from the standard SMD-2B). The fuse interrupting rating, link size and characteristics must be approved by PPL EU.

The 69 kV POC fuses provide clearing for faults in the customer's equipment.

B. Over-current Relays

Three phase (inverse) and one ground (very inverse) relays with time and instantaneous over-current elements connected to current transformers connected on the PPL EU supply line side of each 69 kV or 138 kV FID are required to detect faults in the transformers. This relaying must trip the utility-side POC FID.

PPL EU will approve the relay ranges and settings for these POC relays. The instantaneous attachments of either or both of the phase and ground relays may be blocked from operation by PPL EU.

See the table included at the website: [Accepted Customer Point of Contact and Generator Intertie Protective Devices](#) for a list of acceptable POC relays. If a relay is not included in this list, it is not acceptable for POC duty.

5.2.11 Customer Operating Bus

At 69 kV or 138 kV supply voltages, customer substation 12 kV bus summation or bus differential protection is required for proper operation of the 12 kV bus transfer scheme. PPL EU will review this protection, but will not provide relay settings or calibration of the relays.

5.2.12 Under-voltage Relays

- Each 69 kV or 138 kV source must be provided with three under-voltage relays to monitor the source line voltage.
- These under-voltage relays supervise the automatic transfer and automatic restoration during the loss of the 69 kV or 138 kV source. PPL EU will review this protection, but will not provide relay settings or calibration of these under-voltage relays.

5.2.13 Automatic Transfer Scheme

A. Automatic Transfer Upon Loss of a 69 kV or 138 kV Source

- A hard-wired interlock shall be provided to ensure that when an automatic transfer is initiated, the lost source FID is open before closing the bus sectionalizing FID.
- Loss of the 69 kV or 138 kV line must be detected by under-voltage relays.
- Loss of potential on a single phase shall initiate automatic transfer.
- All transfers are normally initiated with a minimum 2.0 second time delay. This assures that the opposite source is energized before load transfer and that this transfer does not occur during transient system fault conditions.
- Transfers shall not be initiated for a loss of potential resulting from faults in the customer's equipment. The customer's bus protective relays will operate a hand-reset lockout relay, which will trip the associated transformer 12 kV FID and block automatic transfer.

B. Automatic Return to Normal Operation

The customer has the option to include in his control scheme the automatic return to normal operation feature. If the customer chooses this option, the scheme must include the following design criteria:

- A hard-wired interlock must be provided to ensure that the bus sectionalizing FID is tripped before closing the restored source.
- Automatic return to normal operation is initiated only after a three-phase potential check of the restored line.
- Under-voltage relays for 69 kV or 138 kV supply lines initiate the automatic return to normal operation.
- The return shall be initiated with a minimum three-minute time delay setting being specified by PPL EU. The transformer low side FID of the restored source is closed after the bus sectionalizing FID is tripped.
- Automatic unsupervised momentary paralleling of the two source lines is not permitted.

C. Manual Transfer

The selected source FID must be tripped before the 12 kV bus sectionalizing FID can be closed.

D. Manual Return to Normal Operation

During manual return to normal operation, the customer must not at any time close all three FIDs simultaneously. Hard wired interlocks must be provided to prevent any paralleling of the two source lines. The following sequence must be followed to manually return the substation to normal operation:

- Visual three-phase potential check (consisting of indicating lights or voltmeter) on the restored line.
- Trip the bus sectionalizing FID by control switch.
- Close the respective source FID by control switch.

E. Provision to Manually Momentarily Parallel the Two Sources with Prior Approval from PPL EU

- The customer under direction of the regional PPL EU T&D Operations Office can manually close both transformers' low side FIDs and the bus sectionalizing FID for a very short period (only long enough to permit the manual operations to take place). This will permit a load transfer back to either source without dropping load. Prior approval for this type of operation (momentary paralleling of sources) must be obtained from PPL EU.
- During this operating mode, hard-wired interlocks shall be provided to automatically trip one of the FIDs a very short period of time after the three FIDs are closed.

5.2.14 POC Control Requirements

A. Manual Control

- Each 12 kV, 69 kV or 138 kV FID (other than fuses) shall be equipped with a control switch to manually operate the FID.
- POC protective devices must be hard-wired to trip the POC FID. POC relay trip contacts will not trip the POC FID via any type of intermediate microprocessor.
- A three-position transfer selector switch shall be provided to select automatic or manual operation of the 12 kV FIDs.
- A two-position switch NORMAL-PARALLEL with a padlock hasp in the NORMAL position shall be provided to allow PPL EU to momentarily parallel the two sources.

B. Automatic Control

- Automatic reclosing of 69 kV or 138 kV FIDs is not permitted; this is

to prevent automatic reclosing on faulted equipment.

- An automatic transfer scheme will include the following:
 - Each transformer low side FID shall be equipped with a timing scheme to allow a single reclosure attempt when the FID is open and there is potential on the source side of the FID.
 - The bus sectionalizing FID shall be equipped with a timing scheme to allow a single reclosure attempt. The bus sectionalizing FID closes when either line FID has tripped on loss of potential and the opposite line is energized.

C. Indication

- The closed position of each FID shall be monitored with a red indicating light.
- The open position of each FID shall be monitored with a green indicating light.
- Each FID trip coil shall be monitored either by a yellow light or by a red indicating light in series with a FID trip coil and "a" FID auxiliary switch. A "TCM" (trip coil monitor) is also acceptable. If the FID uses a capacitor trip device, the FID trip coil must be monitored by a yellow light in series with a pushbutton. This will allow a manual test of the FID trip coil continuity without placing a constant current drain on the capacitor charge.
- The trip coils of master trip relays shall be monitored with yellow indicating lights.
- Power to control circuits for POC relaying, master trip relay circuits and the FID control circuit shall be supplied via separate fuses. Each fuse shall be monitored for blown fuse or open circuit conditions with a yellow indicating light or annunciator.
- Three-phase AC potential of each line shall be monitored with white indicating lights.
- Annunciator alarms will be indicated or displayed in a location which is normally manned, so that any change of annunciator status is promptly noticed.

D. Test Facilities

POC relays shall be provided with isolation facilities so that all current and potential (if provided) inputs and trip contacts are wired through test points. If not provided by the manufacturer in the form of a draw-out relay case, additional test switches such as the ABB FT1 (or equivalent) must be provided by the customer.

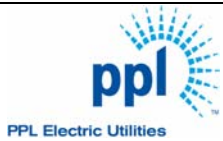

**TRANSMISSION PROTECTION & CONTROL
POINT OF CONTACT REQUIREMENTS FOR
CUSTOMER-OWNED FACILITIES (138 KV & 69 KV)**

EU00513844
Revision: 4
Effective Date: 10/1/2018
Sheet 39 of 86

E. POC Commissioning

For the initial commissioning of a customer's facility, the POC relays will be set and tested by PPL EU Relay Test personnel; PPL EU will also test the CTs (and PTs, if required) which supply the POC relays. Testing will include a full functional test, including tripping of the POC FID device.

5.2.15 Customer's Protection Schemes

The customer may supply protective relays in addition to the required POC relays, at his discretion. These additional relays will be supplied from CTs and PTs separate from the ones used to supply the POC relays. These additional relays will be set at the customer's discretion; if the settings are provided to PPL EU, we will try to set the POC relays to coordinate with the customer's relays, but cannot guarantee optimum coordination.

CUSTOMER TYPE "A-A"

69-12KV OR 138-12KV SUBSTATION

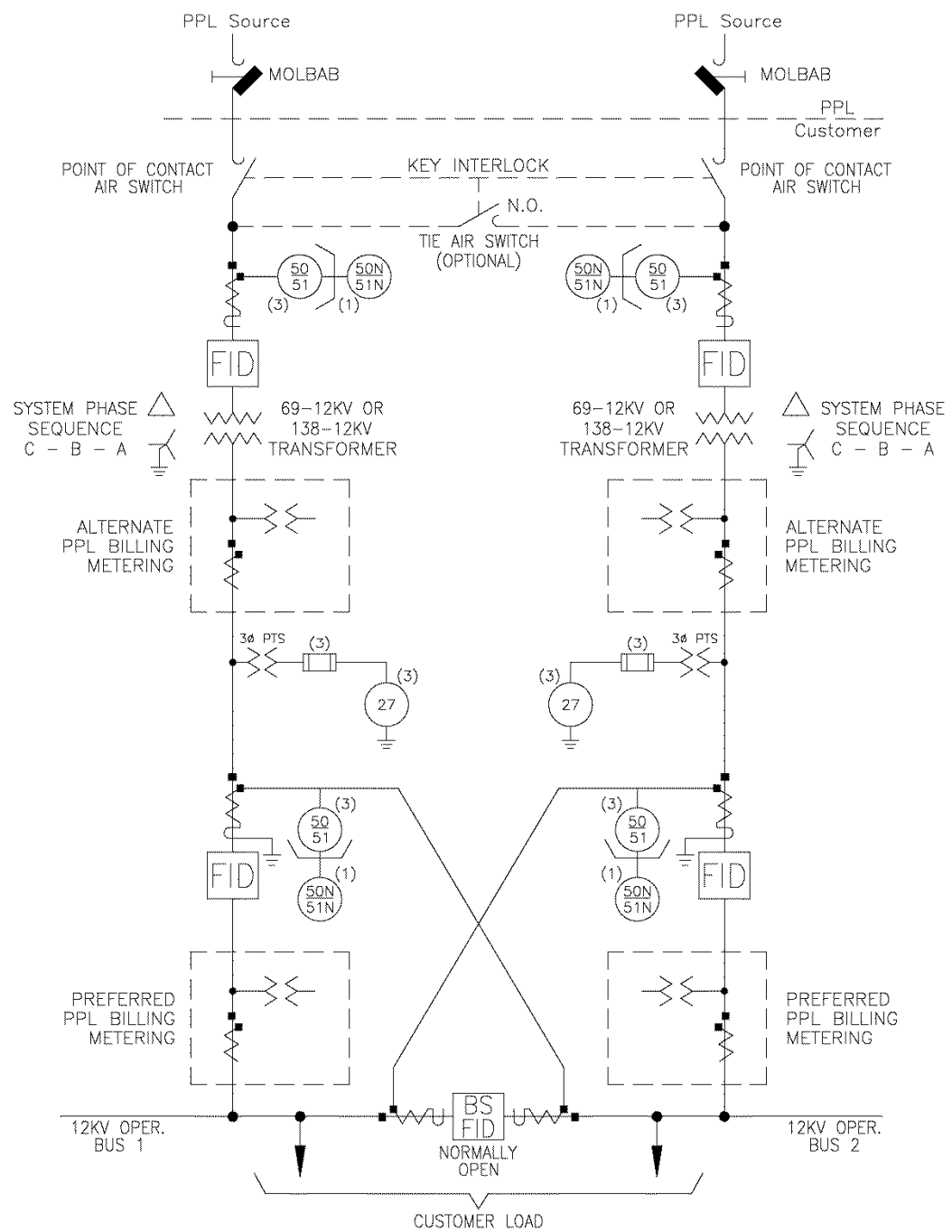

NOTE: At 69kV only, a fuse can be substituted for POC protection instead of the relays and FID.

ONE LINE RELAY/METER

LOCATION CODE: **R073**

5.3 TWO LINE SUPPLY SUBSTATION - CLOSED TIE BETWEEN SOURCES (TYPE B) (See diagram on page 49)

Substation Configuration and Operating Philosophy

The two-line supply (Type B) configuration provides service to the customer via two independent lines of supply. During normal operation as discussed below, the supply lines are paralleled via the customer facility operating bus.

The advantage of this configuration lies in the fact that customer load will not be interrupted following the loss of a utility supply line or a customer's single power transformer.

5.3.1 Configuration

At 69 kV and 138 kV supply voltages, a power transformer is typically installed on each utility line of supply; the parallel between the two supplies is made on the low side of the power transformers via a tie on the customer's bus.

FIDs, such as fuses or circuit breakers or equivalents, are installed on the power transformer high voltage side. FIDs such as circuit breakers or the equivalent are installed between each power transformer low side and the customer operating bus.

The operating bus is sectionalized with a FID other than a fuse or manually operated disconnects.

5.3.2 Normal Operation

Under normal operating conditions, the bus sectionalizing FID is closed, both transformer low side FIDs are closed, and both power transformers are energized and carrying load.

5.3.3 Operation Under Fault Conditions

A. Utility Supply Line Faults

Since the utility supply lines are paralleled through the customer's equipment, directional relaying or over-voltage/under-voltage relays will initiate tripping of the transformer low side FID associated with the faulted supply line. This action isolates the fault and the entire customer load is then supplied by the remaining utility supply line.

B. Power Transformer Faults

At customer substations where a high side fuse is the point of contact protection, a faulted transformer is isolated by blown fuses, and the low side is isolated by opening the FIDs with over/under voltage relaying and/or low side directional relaying schemes.

If a circuit breaker or other relay-supervised device is the FID, then a faulted power transformer will be isolated on the high and low voltage sides by the operation of protective high side over-current relays.

Either of the above actions will isolate the faulted power transformer and isolate the customer operating bus from the fault. The entire customer's load is then supplied by the remaining utility line.

5.3.4 Customer Operating Bus

Each customer operating bus section is typically protected by summation over current or bus differential relaying. This relaying trips and blocks closing of the customer's transformer low side FIDs.

Although not part of the point of contact protection, these protection schemes will be reviewed by PPL EU since operation of these relays opens the PPL EU system supply line parallel.

5.3.5 Other Customer Protective Relays

Additional protective relaying can be applied as required to protect customer equipment including the operating bus and transformers. These customer-specified relays can initiate a trip of the customer's low side FID, but are not considered POC relaying. These additional customer relays must be connected to separate CTs; they may not be connected to the CTs used for POC protective relays.

PPL EU may comment on this additional customer specified relaying, but relay settings are neither specified nor applied by the utility.

If master trip relays are used to open the POC FID, separate master trip relays will be applied for the POC protection and the customer's additional protection; these two separate relay packages will not share a common master trip relay.

5.3.6 Automatic Reclosing

Single shot automatic reclosing can be applied to the transformer low side FIDs. Initiating an automatic reclose, if provided, must only occur following a supply line fault; such fault will be indicated by Type B balanced power, power directional, or over/under voltage relaying operation. Automatic reclosing must be blocked following initiation of a FID trip by transformer differential or operating bus differential protection.

The control logic associated with the transformer low side FIDs will be reviewed by the utility.

Protection and Control Requirements

The following are the POC relaying requirements for two-line supply (Type B) Substations:

5.3.7 Current Transformers

The customer's source 69 kV or 138 kV FIDs and the customer's 12 kV transformer FIDs shall each be equipped with three multi-ratio current transformers (one per phase) to supply the POC relays specified under the section titled Protective Relays.

These CTs must be located on the outer-most position of the PPL EU supply line side of the 69 kV or 138 kV FID bushings, and a separate set of CTs located on the operating bus side of the customer's 12 kV transformer FID. All tap connections of the multi-ratio CTs must be wired out to terminal blocks and be accessible for future CT tap changes.

The POC current transformers must have a relaying accuracy class of C200 or better and be set on a tap such that the maximum available short circuit current does not produce saturation. The customer shall provide CT saturation study results to PPL EU.

The POC CTs must have a voltage rating equal to the FID that they are mounted on or are associated with, and must meet the BIL insulation ratings as specified in Section 1.6.

These current transformers shall not be used as supply to the billing metering equipment, nor any other customer protection or monitoring functions. If additional protection or monitoring functions are desired for the customer's use, additional current transformers shall be supplied suitable for the customer's applications. Current transformers in the 69 kV or 138 kV FIDs for the customer's non-POC use will be located on the inside or customer side of the CTs assigned for POC protection; in other words, the PPL EU POC CTs must be located in the outer-most position on the PPL EU supply line side of the 69 kV or 138 kV POC FID bushings.

PPL EU will review current transformer tap settings proposed by the customer or, if requested, will specify the current transformer tap settings. PPL EU will supply fault current data at the point of the customer's connection to facilitate the proper sizing of the current transformers.

5.3.8 Potential Transformers

The customer will provide three (3) single phase, wye connected, relaying class accuracy, 7200/120 volt-rated potential transformers on the operating bus to supply protective relays specified as POC. When automatic reclosing of the 12 kV transformer FIDs is included in the customer's design, a single-phase potential transformer is required on the transformer side of each 12 kV transformer FID.

These potential transformers shall not be used as supply to the billing metering equipment, nor any other customer protection or monitoring functions. If additional protection or monitoring functions are desired for the customer's use, the potential transformers must be supplied with dual secondary windings—one secondary winding must be reserved for PPL EU point of contact protection facilities. No station service loads such as lights, heaters, etc. should be connected to these potential transformers.

These potential transformers must be able to support the connected relay burden during normal operation and system fault conditions.

5.3.9 Potential Devices

The customer must provide a single-phase capacitive coupling potential device or resistive potential device on each 69 kV or 138 kV supply line to provide potential to over-voltage/under-voltage POC relays.

Similarly, these potential devices shall not be used as supply to the billing metering equipment, station service loads, nor any other customer protection or monitoring functions. If additional protection or monitoring functions are desired for the customer's use, the potential devices must be supplied with dual secondary windings—one secondary winding must be reserved for PPL EU point of contact protection facilities.

5.3.10 Utility Supply Line Fault Protection

A. Over-voltage/Under-voltage Relays

Over-voltage/under-voltage relays are required to protect for phase-to-ground faults on the PPL EU supply lines since 69-12 kV or 138-12 kV power transformers are required with delta-connected windings on the high voltage side and wye-connected windings on the low voltage side.

Following remote terminal clearing for a phase-to-ground fault on a 69 kV or 138 kV supply line, tripping of the related low side transformer FID at the customer's substation is required to eliminate back-feeding a 69 kV or 138 kV line through the customer's equipment.

A relay scheme which can detect this condition requires a single 69 kV or 138 kV potential device connected to one phase to ground on each supply line. Under-voltage and over-voltage relays shall be connected on the secondary of each potential device and will operate a timing relay to trip the low side transformer FID associated with the faulted supply line.

B. Directional Relaying

Because the utility supply lines are paralleled through the customer's equipment, directional relaying is required to initiate tripping of the transformer FID associated with a faulted supply line.

For 69 kV or 138 kV utility supply lines, a balanced power relay scheme is recommended.

1. Balanced Power

- Potential to the directional relays shall be supplied from the 12 kV operating bus potential transformers. A balanced current connection shall be used, i.e., for equal current flow into the operating bus through each 69 kV or 138 kV transformer, the secondary currents at the directional relays shall sum to zero.

The potential and current connections shall be made such that the throw of the relay will enable a trip of the low side transformer FID on the faulted supply line.

- One set of balanced power relays shall consist of two poly-phase direction relays and three phase time over-current relays with very inverse characteristics and instantaneous attachments. A poly-phase directional relay with watt characteristic shall be supervised by the very inverse time over-current relays, and a poly-phase directional relay with a 60 degree maximum torque angle shall be supervised by the instantaneous attachments.
- TOC elements of the over-current relays shall be torque controlled with supervision provided by low side transformer FID status.
- A two-position "Balanced Power Blocking Switch" shall be provided.
- Auxiliary contacts from the main 12 kV FIDs will be incorporated in the balanced power control logic:
 - To provide a seal-in of the trip output until a main FID opens
 - To block the operation of the scheme with one main FID open

2. Operating in Type B Configuration

Prior to paralleling the two PPL EU supply lines through the operating bus, the Balanced Power Blocking Switch or the Power Directional Blocking Switch must be in the "IN" position. After this switch move is made, both FIDs can be closed.

If directional relaying is unavailable, the 69 kV or 138 kV lines must not be paralleled. One method of operation to keep both supply lines in service would be to split the 12 kV operating bus by opening the 12 kV bus section FID or bus sectionalizing disconnects.

5.3.11 Power Transformer Fault Protection

A. Transformer Fuses

At customer's substations with 69 kV service where fuses are installed, the customer shall provide each transformer with 69 kV fuses—S&C Company type SMD-2B (SMD-3C units can sometimes be used if a larger interrupting rating is required—but the customer must discuss with PPL EU before changing from the standard SMD-2B). The fuse interrupting rating, link size and characteristics must be approved by PPL EU.

The 69 kV POC fuses will provide clearing for faults on the customer's equipment.

B. Over-current Relays

Three phase (inverse) and one ground (very inverse) relays with time and instantaneous over-current elements connected to current transformers connected on the PPL EU supply line side of each 69 kV or 138 kV FID are required to detect faults in the transformers. This relaying must trip the utility-side 69 kV or 138 kV POC FID.

PPL EU will approve the relay ranges and settings for these POC relays. The instantaneous attachments of either or both of the phase and ground relays may be blocked from operation by PPL EU.

See the table at website: [Accepted Customer Point of Contact and Generator Intertie Protective Devices](#) for a list of acceptable POC relays. If a relay is not included in this list, it is not acceptable for POC duty.

5.3.12 Customer Operating Bus

Bus differential protection for the low voltage operating bus at 69 kV or 138 kV substations is not considered to be POC protection; however, the customer should consider adding bus differential for fast clearing of bus faults.

PPL EU will review this protection but will not provide relay settings or calibration of these relays.

5.3.13 POC Control Requirements

A. Manual Control

- Each 12 kV, 69 kV or 138 kV FID (other than fuses) shall be equipped with a control switch to manually operate the FID.
- POC protective devices must be hard-wired to trip the POC FID. POC relay trip contacts will not trip the POC FID via any type of intermediate microprocessor.
- Schemes which are designed for manual reclosing of the 12 kV transformer FID upon restoration of the 69 kV or 138 kV supply line do not require contact with the regional PPL EU T&D Operations Office prior to a manual close attempt; however, indication of normal supply line potential must be present prior to the reclose attempt.
- A manual reclose of the 12 kV bus sectionalizing breaker does not require contact with the regional PPL EU T&D Operations Office Operator prior to the reclose attempt.
- If bus differential protection is provided, a bus differential lockout relay contact shall be provided to block manual closing of the 12 kV transformer FIDs. The lockout relay must be reset to allow a manual close of the 12 kV transformer FID.

- If transformer differential protection is provided, a transformer differential lockout relay contact shall be provided to block manual closing of the related low side transformer FID and the 69 kV or 138 kV FID. The lockout relay must be reset to allow a manual close of either FID.

B. Automatic Control

Automatic reclosing of the 69 kV or 138 kV FIDs is not permitted; this requirement is to prevent automatic reclosing on faulted equipment.

The customer has the option to include in his control scheme automatic reclosing of the low side transformer FIDs. If the customer chooses this option, the scheme must include the following design criteria:

- A single shot reclosing relay shall be provided.
- A control switch trip of the FID must block automatic reclosing.
- Automatic reclosing of a low side transformer FID must be blocked following a trip for an operating bus fault.
- Automatic reclosing of a low side transformer FID must be blocked following a trip for a transformer fault.
- Automatic reclosing blocking switches must be provided.
- A potential check of the 69 kV or 138 kV line is required. This potential will be supplied to a potential-check timing relay. Interlocking the potential to the relay with a "b" form auxiliary contact from the transformer FID or from the 12 kV utility line FID is required.
- An automatic reclose attempt shall be initiated after a minimum time delay following the restoration of the 69 kV or 138 kV source. The time delay will be specified by PPL EU.

C. Indication

- The closed position of each FID shall be monitored with a red indicating light.
- The open position of each FID shall be monitored with a green indicating light.
- Each breaker trip coil shall be monitored either by a yellow light or by a red indicating light in series with a FID trip coil and "a" FID auxiliary switch. A "TCM" (trip coil monitor) is also acceptable. If the FID uses a capacitor trip device, the FID trip coil must be monitored by a yellow light in series with a pushbutton. This will allow a manual test of the FID trip coil continuity without placing a constant current drain on the

capacitor charge.

- The trip coils of master trip relays shall be monitored with yellow indicating lights.
- Power to control circuits for POC relaying, master trip relay circuits and the FID control circuit shall be supplied via separate fuses. Each fuse shall be monitored for blown fuse or open circuit conditions with a yellow indicating light or annunciator alarm.
- Annunciator alarms will be indicated or displayed in a location which is normally manned, so that any change of annunciator status is promptly noticed.
- Three-phase AC potential from each line used for POC relaying shall be monitored with white indicating lights.
- Transformer low side AC potential shall be monitored with a white indicating light.

D. Test Facilities

POC relays shall be provided with isolation facilities so that all current and potential (if provided) inputs and trip contacts are wired through test points. If not provided by the manufacturer in the form of a draw-out relay case, additional test switches such as the ABB FT1 (or equivalent) must be provided by the customer.

E. POC Commissioning

For the initial commissioning of a customer's facility, the POC relays will be set and tested by PPL EU Relay Test personnel; PPL EU will also test the CTs (and PTs, if required) which supply the POC relays. Testing will include a full functional test, including tripping of the POC FID device.

5.3.14 Customer's Protection Schemes

The customer may supply protective relays in addition to the required POC relays, at his discretion. These additional relays will be supplied from CTs and PTs separate from the ones used to supply the POC relays. These additional relays will be set at the customer's discretion; if the settings are provided to PPL EU, we will try to set the POC relays to coordinate with the customer's relays, but cannot guarantee optimum coordination.

CUSTOMER TYPE "B"

69-12KV OR 138-12KV SUBSTATION

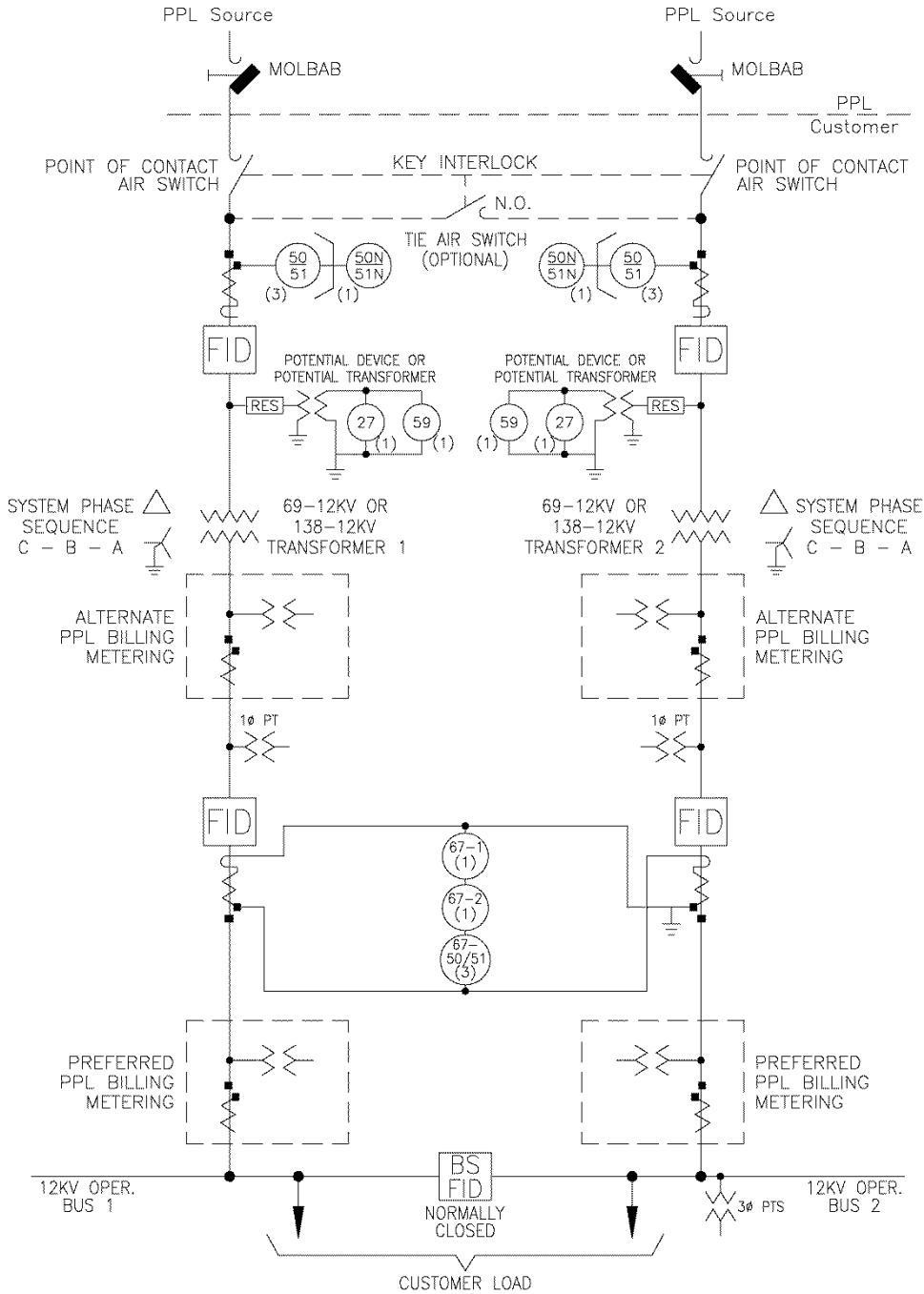

NOTE: At 69kV only, a fuse can be substituted for POC protection instead of the relays and FID.

ONE LINE RELAY/METER

LOCATION CODE: **R073**

5.4 PPL EU BILLING METERING

All CTs, PTs, and meters for Billing Metering will be provided by PPL EU along with all necessary information about metering requirements.

No relays or other meters are to be connected to the CTs and PTs used for Billing Metering. Similarly, no customer substation loads will be connected to billing metering CTs or PTs.

The preferred location for the PPL EU Billing Metering CTs and PTs is on the customer's operating bus side of the low voltage FID. If the customer adds a second supply line or installs emergency standby generation (or if the customer plans to add these facilities in the future), he may want to consider adding a disconnect switch between the billing metering CTs and PTs and the operating bus. This additional disconnect switch will allow the customer's operating bus to remain energized via the alternate source (the other supply line or emergency standby generation) if the metering, metering CTs or metering PTs must be maintained or replaced.

An alternate location for the PPL EU Billing Metering CTs and PTs is between the power transformer and the transformer low voltage FID.

These CTs and PTs must be protected by the POC protection relays and FIDs.

5.5 OPERATING TRANSFORMERS

All substation loads, such as battery chargers, lights, heaters, etc., will be supplied from operating transformers. These operating transformers must be connected such that the billing metering will record the usage of the load connected to them.

The sole exception to this policy occurs if the operating transformers are connected to the customers load side of a FID, which requires AC voltage for its control circuits. In this case, a separate operating transformer with a maximum rating of 1.5 kVA, may be connected to the supply side of the FID and is permitted for FID control only. No other station load is to be connected to this operating transformer.

5.6 MICROPROCESSOR-BASED RELAYS, PROGRAMMABLE LOGIC CONTROLLERS (PLC), TRIPPING SOURCES, AND REMOTE ALARMS

If the customer chooses multifunction microprocessor-based relays and programmable logic controllers as the POC protection and control of the substation, the following requirements must be met:

5.6.1 Multifunction Microprocessor-based Relays

- Sources that supply microprocessor-based relays must be uninterruptible. (Relays which are powered from the current transformers and do not require separate power supplies are preferable.)

- With the trend to using microprocessor-based relays, and the tendency to include all of the required POC protection in a single device, failure of this one device must be considered. PPL EU strongly recommends that two (2) independent relays be provided, such that failure of the one relay will allow continued operation of the customer's facility until the failed relay can be repaired or replaced. Failure of a single POC relay installation will require the immediate disconnection of the customer's facility for the PPL EU system.

Alternatively, an independent ground over-current relay can be provided. This will ensure that there is protection if the primary relay fails. When the primary relay fails or must be taken out of service for maintenance, the application of an independent ground over-current relay will permit the maintenance work or repair work to be done without taking the customer out of service.

- Control logic included in a microprocessor POC relay shall not be used to provide control functions of the FID.

5.6.2 Programmable Logic Controllers

When customers choose Programmable Logic Controllers (PLCs) for control, all FID tripping must be accomplished via hard-wired control circuits and must operate independently of the PLC controls. This is required for trip functions from:

- POC relays (including differential and/or summation over-current relay schemes, if considered to be part of the POC protection package)
- Control switches—trip and closing functions
- Automatic source transfer schemes (such as are permitted at customer substations with two supply sources, including customer-owned generation)

PLC control schemes are permissible for automatic operations such as source transfers of the POC FIDs, but the PLC controls must be “backed up” or duplicated by hard-wired interlocks provided to prevent paralleling the utility supply lines.

5.6.3 Tripping Sources and Remote Alarms

- FID trip controls must be via DC supply; either battery/charger systems or capacitive trip devices are acceptable.
- Provisions must be made to remotely monitor DC power sources, microprocessor-based relays, and PLC failures. In general, all device alarms (such as loss of AC potential, relay failure, loss of control power, battery charger alarms, etc.) should be connected to a central annunciator or monitoring panel. All POC equipment alarms (whether indicating lights, annunciators, or horns/strobe lights), must be routed to a manned location where the alarm condition will be noticed and analyzed in a timely manner. PPL EU must be notified, and corrective actions planned, as soon as possible.

5.7 RELAY TEST COMMISSIONING PROCEDURES

The Relay Test Department at PPL EU provides technical support for the initial commissioning of customer point-of-contact (POC) installations involving systems with protective relays. They should be included in the early review of customer POC systems, along with other key PPL EU groups, to help the customer to develop an optimum design.

As the POC work progresses to the physical construction stage, Relay Test will participate in the initial "on-site" job meeting and will develop a work plan to support all issues of concern to Test which are required to connect the customer to the PPL EU system.

These include the initial commissioning tests for all equipment related to acceptance of the POC protection and control schemes:

- 1) Relay acceptance tests and calibration of settings, issued by PPL EU.
- 2) Current Transformer tests.
- 3) Current Transformer saturation tests
- 4) Current circuit verification.
- 5) Potential circuit verification.
- 6) Control circuit tests.
- 7) In-service verification tests.
- 8) Secure the relay from tampering by use of a software password or by applying a PPL EU seal; as applicable to the relay type.
- 9) Plus any other issues related to the POC systems.

PPL EU Relay Test personnel will complete items 1, 7 and 8. Items 2 through 6 can be done by the customer's contractor and witnessed by Relay Test employees, or completed by Relay Test with customer participation as appropriate.

PPL EU Relay Test personnel will require a written commissioning procedure proposed by the customer's contractor. This procedure should cover a step-by-step listing of the tests required to ensure that the customer's POC schemes operate properly. This initial commissioning procedure should be supplied to PPL EU at least two weeks prior to the scheduled in-service testing process; a delay in receipt of the customer's commissioning procedure could cause a delay of the in-service date.

One of the responsibilities of the PPL EU Relay Test personnel is to secure the POC relays upon successful completion of the commissioning procedure. If a cabinet is provided to house the POC relay package, the cabinet door will be secured with a suitable lock. If a cabinet is not provided or if securing the entire cabinet with a lock is not practical, then the POC relays will be secured via use of a seal or passwords to limit access. The POC protection equipment is installed to protect the PPL EU system from adverse effects of the customer's equipment. For this reason, control of this equipment must remain with PPL EU.

Customers are billed for work done by PPL EU outside of the "core working hours" and should be aware of this policy.

5.8 COMMISSIONING PROCEDURES FOR NON-RELAYED POC PROTECTION

For customer installations with POC protection which does not consist of relays--in other words, if the POC protection is provided by fuses--the PPL EU Relay Test Department does not get involved with commissioning tests.

If the customer has fuses for the POC protection and has a 12 kV or lower voltage transfer scheme to switch the customer's load between either:

- two lines of supply from PPL EU, or
- from the PPL EU supply line to a customer-owned emergency standby generator,

then a PPL EU representative will witness proper operation of the customer's transfer scheme before the customer is allowed to energize his equipment. The customer must operate the transfer scheme and show the effectiveness of the required hard-wired interlocks to prevent:

- paralleling of the two PPL EU supply lines, or
- paralleling of the emergency standby generator with the PPL EU system.

PPL EU will require a written commissioning procedure proposed by the customer or his contractor. This procedure should cover a step-by-step listing of the tests required to ensure that the customer's transfer schemes operate properly. This initial commissioning procedure should be supplied to PPL EU at least two weeks prior to the scheduled in-service testing process; a delay in receipt of the customer's commissioning procedure could cause a delay of the in-service date.

SECTION 6 MAINTENANCE

Maintenance of customer's equipment is important to assure reliable operation of the PPL EU system. Failure of the Point of Contact protective relaying and/or interrupting device to isolate a customer's internal fault requires the PPL EU remote substation protection to recognize the fault and clear it (but an additional time delay is required to allow for coordination). The remote clearing of a customer's internal fault subjects every other customer on that same supply line to the fault conditions and a power interruption. This degrades the power quality and reliability for the other customers and increases the possibility of equipment damage and danger to the public.

Accordingly, PPL EU strongly recommends that customers arrange for periodic testing and calibration of their substation facilities, both the PPL EU-required point of contact protection package, including the fault-interrupting device, and the customer's own protection packages. The maintenance chart on the next page is intended to serve as a suggestion for appropriate maintenance practices, based on the maintenance which PPL EU performs in our own substations. While adherence to a deliberate maintenance program cannot ensure that misoperations and failures will not happen, a conscientious maintenance program can minimize the possibilities.

Neither PPL Electric Utilities nor any person acting on behalf of PPL Electric Utilities:

- Assumes any liabilities with respect to the use of this list of maintenance items, or damages resulting from conducting these maintenance activities,
- Nor provides any warranty that following the suggested maintenance activities will prevent any or all equipment failures,
- Nor guarantees that this list constitutes the minimum of maintenance which is required for the customer's particular substation. The equipment manufacturers are to be consulted on the maintenance requirements for their particular equipment and any discrepancies with the following list of suggested maintenance activities must be resolved per the manufacturer's recommendations.

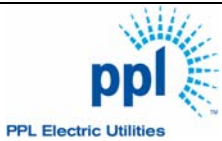

Suggested Testing and Maintenance Activities for HV Customers

Suggested Point-of-Contact Maintenance Activities

Maintenance Item
Physical inspection of hardware, insulation and current-carrying conductors/bus
POC Relay setting verification and/or calibration *
POC relay functional test (up to and including tripping of the FID) *
Test equipment alarms and remote indications of alarms for POC equipment
CT and PT calibration check (devices used for POC protection)
Battery charger testing, battery load and specific gravity testing
Exercise interrupting device (for circuit breakers, circuit switchers or disconnect switches)
Clean & Lube physical switches, mechanisms and other required components
Fuse coordination review/replacement
Infrared/Ultrasound measurements of energized equipment
Power factor test of lightning arrestors, CTs, PTs, CCVTs
Insulating medium: SF ₆ purity and moisture testing and/or oil dielectric testing

* The PPL EU Relay Test Personnel will complete these items or must witness the testing and maintenance since the POC relays are secured for PPL EU personnel access only. See reference in Section 5.7.

Suggested Non-Point-of-Contact Maintenance Activities

Maintenance Item
Large Power Transformer oil quality testing <ul style="list-style-type: none"> • Dissolved Gas Analysis—ppm of 9 combustible gases • Neutralization Number (D974) ** • Interfacial Tension (D971) ** • Dielectric (D1816) ** • Specific Gravity (D1298) ** • Visual Sediment (D1524) ** • ASTM Color (D1524) ** • Water Content (D1533) ** • Power Factor at 25°C and 100°C (D924) **
Transformer total turns ratio, power factor, winding resistance and watts loss testing
Bushing power factor testing
Battery replacement for recloser control box (for 12 kV customers)
De-energize, rack out & visual inspection of switchgear POC breaker (for 12 kV customers)

** The “D” numbers are the ASTM standard numbers that describe the testing and methodology that is used.

NOTE: PPL EU is not specifying frequencies for these suggested maintenance and testing activities. The equipment manufacturer’s service manuals should offer recommended frequencies of inspection, as well as additional suggested activities. In addition, testing and maintenance guidelines can be found in several industry documents, such as:

- IEEE Standards
- National Electrical Testing Association
- National Fire Prevention Association, Standard NFPA 70B, Recommended Practice for Electrical Maintenance

SECTION 7 DRAWING REQUIREMENTS

7.1 DRAWINGS AND INFORMATION FOR REVIEW

PPL EU will require the following drawings and information for review and acceptance:

- One Line Diagram *
- Three Line Diagram*
- Transmission Line Dead-end Structure (proposed/final)
- Plan and Elevation Views (electrical arrangements only)*
- General Arrangement Drawing
- Grounding Plan and Details
- Ground Test Report (when customer substation is complete but before PPL EU supplies are connected) *
- Bill of Material (major electrical equipment only, including switch, protective device, transformer, surge arresters, relays, etc.) *
- Switch Interlock Schematic and Details
- Three Line Potential Elementary*
- Three Line Current Elementary *
- Control Elementary drawings, for each 12 kV, 69 kV or 138 kV FID *
- Power Transformer Certified Test Report(s)
- Front view showing POC Relay and Control Equipment *
- Detailed worded descriptions of Point of Contact (POC) relay and control functions and description of operation. *
- Commissioning procedure *
- POC relay instruction book *
- POC CT saturation study *
- Auto transfer switch make and model (if customer-owned backup generation is installed)

* Denotes drawings which must be supplied for every type of customer facility.
Other drawings must be supplied as applicable.

7.2 CONTENTS OF DRAWINGS

The customer's POC drawings shall contain the following information:

7.2.1 One Line Relay Diagrams

This drawing shows the customer's substation functional arrangement. All the equipment shall be shown using single-line diagram and standard symbol notations (per latest ANSI/IEEE Standard 315; titled Graphic Symbols for Electrical and Electronic Diagrams). This drawing shall include:

1. Equipment names and/or numerical designations for main FIDs, air switches, power transformers, and associated POC relays and control devices shall be shown to match with PPL EU line designation. (Note: The required information will be provided by PPL EU after the customer submits

a preliminary one line diagram.)

2. Power Transformers - Nominal kVA, nominal primary/secondary and tertiary voltages and vector diagram.
3. Instrument Transformers - Voltage and current transformers that supply the POC relaying.
4. Lightning Arresters/Spill Gaps/Surge Capacitors - Ratings.
5. Air Switches - Indicate status normally open with a (N.O), normally closed with a (N.C.) and type of operation manual or motor.
6. Safety Switch - Continuous ampere and interrupting ratings.
7. FIDs - Interrupting rating, continuous rating, operating times.
8. Transformer Fuses - Size, type, location.
9. Grounding.

7.2.2 Three Line Current Elementary Diagrams

1. Terminal designations of all devices - Relay coils and contacts, switches, transducers, etc.
2. Relay Functional Designation - Per latest version of ANSI/IEEE standard C-37.2. The same functional designation shall be used on all the drawings showing the relay.
3. Complete relay type such as "SEL 321", etc., and the relay range.
4. Range and settings of timing relays.
5. Switch developments and escutcheons shall be shown on the drawing where the majority of contacts are used. If contacts of a switch are used on a separate drawing, that drawing should be referenced adjacent to the contacts in the switch development. Any contacts not used should be referenced as spare.
6. All switch contacts are to be shown in the open position with each labeled to indicate the positions in which the contacts will be closed.
7. Switch contacts shall be referenced to the switch development if development is shown on a separate drawing.
8. Isolating points (States sliding links, test switches, etc.).
9. Grounding of CT cables.
10. All other circuit elements and components with device designation, rating,

and setting where applicable.

11. Current Transformers - Polarity marks, rating, tap, ratio, and connection.
12. Auxiliary CTs -- ratios, connections and polarity, current ratings of windings and arrows to indicate assumed current flow.
13. Phase designations and rotation of both PPL EU and customer.
14. Cable connection number or wire designation.

7.2.3 Three Line Potential Elementary Diagrams

1. Terminal designations of all devices – relay coils and contacts, switches, transducers. etc.
2. Relay Functional Designation - Per latest version of ANSI/IEEE standard C-37.2. The same functional designation shall be used on all the drawings showing the relay.
3. Complete relay type such as "SEL 321", etc., and the relay range.
4. Relay contacts shall be referenced to the drawing when the coil is shown, provided the coil is shown on a separate drawing.
5. Relay contacts should be shown with each referenced to the drawing where they are used. Contacts not used should be referenced as spare.
6. Range and settings of timing relays.
7. Switch developments and escutcheons shall be shown on the drawing where the majority of contacts are used. If contacts of a switch are used on a separate drawing, that drawing should be referenced adjacent to the contacts in the switch development. Any contacts not used should be referenced as spare.
8. All switch contacts are to be shown in the open position with each labeled to indicate the positions in which the contacts will be closed.
9. Switch contacts shall be referenced to the switch development if development is shown on a separate drawing.
10. Isolating points (States links, test switches, etc.).
11. Grounding of cables.
12. All other circuit elements and components with device designation, rating, and setting where applicable.
13. Coil voltage for all auxiliary relays.

14. Potential transformer – nameplate ratio, polarity marks, rating, primary and secondary connections.
15. Phase designations and rotation of both the utility and customer.
16. Current ratings and designation of all fuses.

7.2.4 Control Elementary Diagrams

Control elementary drawings are to be functionally complete schematics. They should be as simple and uncluttered as possible, and shall contain the following information:

1. Terminal designations of all devices – relay coils and contacts, switches, transducers, etc.
2. Relay Functional Designation - Per latest version of ANSI/IEEE standard C-37.2. The same functional designation shall be used on all the drawings showing the relay.
3. Complete relay type such as "SEL 321", etc., and the relay range.
4. Range and settings of timing relays.
5. Switch developments and escutcheons shall be shown on the drawing where the majority of contacts are used. If contacts of a switch are used on a separate drawing, that drawing should be referenced adjacent to the contacts in the switch development. Any contacts not used should be referenced as spare.
6. All switch contacts are to be shown in the open position with each labeled to indicate the positions in which the contacts will be closed.
7. Switch contacts shall be referenced to the switch development if development is shown on a separate drawing.
8. Isolating points (States links, test switches, etc.)
9. All other circuit elements and components with device designation, rating, and setting where applicable.
10. Cable connection number or wire designation.
11. Device auxiliary switches (FIDs, contactors) should be referenced to the drawings where they are used.
12. Any interlocks; electromechanical, key, etc.
13. Coil target ratings; on dual ratings underline the appropriate tap setting.

14. Complete internals for electromechanical protective relays. Solid-state relays may be shown as a "black box," with power supply and output connections, but manufacturer's instruction book number shall be referenced and terminal designations shown.
15. DC fuses protecting the point of contact relaying and FID control circuits shall be monitored for blown fuse or open circuit with a yellow indicating light.
16. The trip coils of lockout relays should be monitored.
17. The coils and contacts of all timers and lockout relays shall be wired through States links or equivalent terminal blocks to provide isolation for testing.

7.2.5 Front View Diagrams

This drawing will show the physical arrangement of all the control and protective equipment for the POC relaying and shall contain the following information:

1. Nameplates shall be provided for all switches, lights and hand reset lockout relays for the purpose of identification.
2. The POC relaying shall be mounted and grouped in such a way as to be clearly differentiated from the other customer's relaying. The POC relaying may be located on a separate area within a relay panel housing other customer's relays.
3. The POC relaying shall be mounted on the switchboards in such an order that equipment associated with the various phases will be in A-B-C order from top to bottom or from left to right when facing front of panel on which they are mounted.

7.2.6 General Arrangement Drawing

This drawing will show the overhead arrangement of the substation and all above ground equipment, structures, enclosures, etc. The following information shall be included on this drawing:

1. A North arrow shall be shown to establish the geographic orientation of the substation.
2. Phase designations for all substation power conductors shall be included on this drawing. The phases shall be labeled on the high side as well as the low side of the power transformer(s).
3. PPL EU's incoming transmission line conductors shall be shown with the phase designation of each conductor clearly identified.

7.3 DRAWING APPROVAL PROCEDURES

- 7.3.1 The customer must submit preliminary POC relaying and General Arrangement drawings for PPL EU review and acceptance. These drawings must be submitted before the customer's equipment is ordered to ensure that it meets PPL EU requirements.
- 7.3.2 The customer must submit final POC relaying and General Arrangement drawings for PPL EU review and acceptance before the customer's facilities will be allowed to be connected to the PPL EU system and placed in-service. PPL EU will not be held responsible for possible late connection of customer's facilities if drawings are not received in time for review.
- 7.3.3 The type of drawings submitted must be according to the list described under "Type of Drawings Required."
- 7.3.4 All drawings submitted to PPL EU for acceptance must contain complete information as outlined under "Contents of Drawings."
- 7.3.5 The drawings submitted by the customer to PPL EU for review apply only to POC switching devices and POC relaying.
- 7.3.6 PPL EU will review the customer's drawings and provide comments within 15 working days from the day a complete set of drawings and information are received by Substation Engineering.
- 7.3.7 Specific Grading Plan, Foundation Plan, Foundation Details, Conduit Plan, Structural Steel Assembly, and Structural Steel Fabrication Detail drawings do not require PPL EU review.
- 7.3.8 The responsibility of detail and correct design lies with the customer. Neither PPL EU nor any person acting on behalf of PPL EU:
- Assumes any responsibility for correctness of design, drawings, installation, or operations.
 - Assumes any liability with respect to the use of, or from damages resulting from the use of, any comments disclosed in this document or in any other PPL EU correspondence with the customer.

7.4 FINAL AS-BUILT DRAWINGS

The customer must provide two (2) copies of the As-Built drawings listed in Section 7.1. Also include copies of any and all inspection certificates with the copies.

SECTION 8 LIST OF APPLICABLE ANSI/IEEE STANDARDS

- ANSI/IEEE C2-2012, National Electrical Safety Code.
- ANSI/IEEE C37.010-1999, Application Guide for AC High-Voltage Circuit Breakers Rated on a Symmetrical Current Basis.
- ANSI/IEEE C37.2-2008, Standard Electrical Power System Device Function Numbers.
- ANSI/IEEE C37.5-1979, Guide for Calculation of Fault Current for Application of AC High-Voltage Circuit Breakers Rated on a Total Current Basis.
- ANSI/IEEE C37.90-2005, Relays and Relay Systems Associated with Electric Power Apparatus.
- ANSI/IEEE C37.91-2008, Guide for Protective Relay Applications to Power Transformers.
- ANSI/IEEE C37.93-2004, Guide for Power System Protective Relay Applications of Audio Tones over Telephone Channels.
- ANSI/IEEE C37.99-2012, Guide for Protection of Shunt Capacitor Banks.
- ANSI/IEEE C37.101-2006, Guide for Generator Ground Protection.
- ANSI/IEEE C57.13-1993, Standard Requirements for Instrument Transformers.
- ANSI/IEEE Std. 141-1993, Recommended Practice for Electric Power Distribution for Industrial Plants (IEEE Red Book).
- ANSI/IEEE Std. 241-1990 (R1997), Recommended Practice for Electric Power Systems in Commercial Buildings (IEEE Gray Book).
- ANSI/IEEE Std. 242-2001, Recommended Practice for Protection and Coordination of Industrial and Commercial Power Systems (IEEE Buff Book).
- ANSI/IEEE Std. 315-1975 (R1989), Graphic Symbols for Electrical and Electronics Diagrams.
- ANSI/IEEE Std. 446-1995 (R2000), Recommended Practice for Emergency and Standby Power for Industrial and Commercial Applications (IEEE Orange Book).
- ANSI/IEEE Std. 493-2007, Recommended Practice for the Design of Reliable Industrial and Commercial Power Systems (IEEE Gold Book).
- ANSI/IEEE Std. 519-2014 IEEE Recommended Practices and Requirements for Harmonic Control in Electric Power Systems.
- ANSI/NFPA 70-2014, National Electrical Code.
- IEEE Std. 80-2013, Guide for Safety in AC Substation Grounding.
- IEEE Std. 81-2012, Guide for Measuring Earth Resistivity, Ground Impedance and Earth Surface Potentials of a Ground System.
- ANSI/IEEE 37.102-2004 (R2012), Guide for AC Generator Protection.
- IEEE Std. C37.110-2007, IEEE Guide for the Application of Current Transformers Used for Protective Relaying Purposes.
- ANSI/IEEE C57.105-1978 (R1992), IEEE Guide for Application of Transformer Connections in Three-Phase Distribution Systems

APPENDIX

REQUIREMENTS FOR CUSTOMER EMERGENCY STANDBY GENERATION

1.0 GENERAL POINTS FOR CUSTOMER-OWNED GENERATION

- 1.1 Generation that the customer installs can be grouped into the following categories:
 - 1.1.1 Emergency standby generation
 - 1.1.2 Load off-setting or peak shaving generation
 - 1.1.3 Distributed Generation / Distributed Resources
 - 1.1.4 Independent Power Production
- 1.2 Reference should be made to “Rules for Electric Metering & Service Installation” (REMSI) found at PPL EU website: [REMSI \(Rules for Electric Meter & Service Installations\)](#) as appropriate for the given design. Typically, an emergency standby installation with a single-line utility supply and no parallel operation with the customer’s generator-set is covered by REMSI criteria.
- 1.3 The general design criteria should be such that the final installation on the customer’s premise does not create a facility that can cause a safety hazard **to** the PPL Electric Utilities power system, nor create a connection configuration whereby the customer’s facility is not adequately protected from the available power of the utility system. All applicable codes, standards, and regulations are the responsibility of the customer or the customer’s design consultant / representative.
- 1.4 **Emergency Standby Generation**
 - 1.4.1 “Emergency standby generation” is a generation facility that is installed by the customer and used when the utility supply becomes disrupted. Upon restoration of the utility supply, the emergency standby generation is shut off. It is not intended to generate in parallel with PPL EU’s system for any appreciable amount of time, except to allow the customer’s system to transfer back to PPL EU.
 - 1.4.2 Any installation by the customer of emergency standby generation must be coordinated with the requirements of REMSI or this document, whichever is most relevant to the design of the installation.
 - 1.4.3 For installations where the transfer is provided via **manual double- throw switches**, please refer to REMSI sketch 41 series.
 - 1.4.4 For installations where the transfer is provided via **auto transfer switches** that are open transition (break-before-make) devices **and** are also electrically operated/mechanically held, please refer to REMSI sketch 41 series.

- 1.4.5 The installations noted above are for designs via **open transition operation** (break-before-make), either manual or automatic, as shown on Figure A-1, page 72.
- 1.4.6 For all other types of installations, please refer to the paragraphs below, as well as to other sections within this document for additional information. Also, contact PPL Electric Utilities prior to development of detailed design and purchase of equipment.

1.5 Load Off-Setting or Peak Shaving Generation

- 1.5.1 “Load Off-Setting” or “Peak Shaving” are generation facilities that are installed by the customer for the purpose of selectively capping the amount of load that is supplied by the utility for an extended period of time. A generator that operates to offset load is referred to as operating “behind the meter”.
- 1.5.2 For these types of installations, Rule 6 of “Rules for Electric Service” (tariff) may apply. This will require the installation of additional metering and will be subject to special contract requirements and billing criteria. Please contact PPL Electric Utilities for contractual details and metering information prior to development of this type of scheme.
- 1.5.3 For such Load Off-Setting or Peak Shaving installations, this document should address most of the technical issues, but additional technical criteria may be specified for the installation. Please contact PPL Electric Utilities prior to development of detailed design and purchase of equipment. Specific requirements for parallel operation of customer- owned generation with the PPL EU system can be found at the website: [Relay and Control Requirements for Parallel Operation of Generation \(138 kV & 69 kV\) \(EU00530561\)](#).

1.6 Distributed Generation

- 1.6.1 “Distributed Generation” or “Distributed Resources” are small scale generation facilities that are connected to the distribution system. These are typically small units, inverter based, installed by the customer, use renewable energy sources and covered by PA State regulations. These installations do not sell output to the PJM.
- 1.6.2 For requirements related to installation of distributed generation facilities, please contact PPL Electric Utilities Business Accounts Department at telephone number 1-888-220-9991, menu option 4, to obtain specific information on these types of installations. Distributed generation requirements are not covered in this document; protection and control requirements for parallel operation of larger customer-owned generators with the PPL EU system can be found in the document at the website: [Relay and Control Requirements for Parallel Operation of Generation \(138 kV & 69 kV\) \(EU00530561\)](#).

1.7 Independent Power Production

- 1.7.1 “Independent Power Production” or “IPP” are generation facilities that are installed by the customer for the purpose of selling the power to the grid.
- 1.7.2 For requirements related to installation of IPP facilities, please contact PJM LLC at www.pjm.com
- 1.7.3 Neither technical nor contractual requirements of PJM are covered by this document. Specific requirements for parallel operation of customer- owned generation with the PPL EU system can be found at the website: [Relay and Control Requirements for Parallel Operation of Generation](#).

2.0 DRAWINGS FOR REVIEW

- 2.1 Information to be submitted for review should include the following information, as appropriate for the proposed installation:
 - 2.1.1 One Line Diagram – must show electrical configuration and connection with utility supply, generator set, and transfer scheme.
 - 2.1.2 Description of operation of the scheme.
 - 2.1.3 Manufacturer / model number of the autotransfer switch / transfer scheme equipment. If the autotransfer switch is not on the list of accepted equipment, the manufacturer literature and drawings on autotransfer switch / transfer scheme equipment are to be provided for review. See the REMSI website (in Section 9) for the list of approved open transition autotransfer switches.
 - 2.1.4 Generator – voltage and size information.
 - 2.1.5 Wiring drawings for autotransfer switch or autotransfer scheme.
 - 2.1.6 Any additional information that would be appropriate for review.

3.0 TRANSFERS AT LESS THAN 600 VOLTS

- 3.1 Refer to REMSI Sketch 41 series for emergency standby generation designs that meet **all** of the following:
 - 3.1.1 The utility source as a single circuit supply, and,
 - 3.1.2 The transfer scheme uses manual double throw switches or auto transfer switches that are electrically operated / mechanically held, and,

- 3.1.3 The transition is open transition (break-before-make) for all transfers (normal-to-emergency, and emergency- to-normal), and,
- 3.1.4 The autotransfer switch is listed as a device that has been reviewed and is acceptable for connection with the PPL Electric Utilities system, (as noted on the list of accepted autotransfer switches), and,
- 3.1.5 The auto transfer switch does **not** use molded case circuit breakers.
- 3.2 For emergency backup generation schemes that do not meet **all** conditions that are listed in Appendix Section 3.1 above, the information and electrical diagrams contained in subsequent paragraphs should be followed.
- 3.3 Please contact PPL Electric Utilities for discussions and reviews of any designs or equipment that are not included within the scope of the information in this book.
- 3.4 Figures A-1 through A-9 should be used as references in this section. These sketches are generic in nature and should be used as guidance for engineering a design that falls in line with the general criteria for connecting to, and operating with, the PPL Electric Utilities system.
- 3.5 **Categories of Transitions** - the following categories of transitions are acceptable for use on installations rated less than 600 volts and that make electrical connections with the PPL Electric Utilities system. These include:
 - 3.5.1 Open Transition – break-before-make operation in transfers made in both the normal-to-emergency transitions, and the emergency-to-normal transition. This is the **preferred** transfer mode.
 - 3.5.2 Closed Transition – with overlap made between the customer’s generator and the utility source. The overlap duration must be less than 100 milliseconds.
 - 3.5.3 Extended Closed Transition – with an extended overlap made between the customer’s generator and the utility source. This extended overlap duration must be less than 5 minutes.
- 3.6 **Equipment for power transfers** – the following equipment can be used to facilitate the transfer between the utility and the generator. The proper specification and design of the equipment and transfer scheme is the responsibility of the customer/customer’s consultant. Key interlock systems are acceptable for use at installations.
 - 3.6.1 Manual double-throw switch
 - 3.6.2 Electrically operated, mechanically-held autotransfer switch
 - 3.6.3 Mechanical linkage operated, molded case circuit breakers (operated with motor or solenoid)
 - 3.6.4 Electrically operated circuit breakers.

3.7 Protection and Control Criteria

- 3.7.1 If the transfer switch is manual or if it is an auto transfer / open transition switch (electrically operated, mechanically held), protection and control criteria for the generator is based solely on the customer's criteria. No additional protective devices or interlocks are required for design acceptance. Refer to Figure A-1, page 72.
- 3.7.2 If the transfer switch is electrically operated / open transition, molded case circuit breakers (operated with motor or solenoid), then the design of the switch must be reviewed by PPL Electric Utilities to insure that, upon failure within the transfer switch, paralleling of sources does not occur. Hard wired interlocks must be installed. Hard wired interlocks must be wired in a manner to prevent the inadvertent closure of both circuit breakers. Refer to Figure A-2, page 72.
- 3.7.3 If the transfer switch is mechanical linkage operated / open transition, molded case circuit breakers (operated with motor or solenoid), then the design of the switch must be reviewed by PPL Electric Utilities to insure that, upon failure within the transfer switch, paralleling of sources does not occur. A solid mechanical interlock must be part of the design of the transfer switch. Refer to Figure A-3, page 73.
- 3.7.4 If the auto transfer / closed transition switch (electrically operated, mechanically held), protection and control criteria must include hard wired interlocks with timer to prevent paralleling to remain beyond the maximum allowed interval of 100 milliseconds (prefer a setting of 80 msec to 90 msec). Tripping of the generator circuit breaker by a separate timer (located in the generator controls), set between 100 msec and 150 msec, is required. Alarming by the timer is recommended. Refer to Figure A-4, page 74.
- 3.7.5 If the auto transfer switch is developed with electrically operated circuit breakers, controlled with a microprocessor controller, then hard wired interlocks with timer, wired from the auxiliary switches on each circuit breaker, must be included. This feature must be included to prevent continued paralleling of the generator with the utility to remain beyond the maximum allowed interval (as described below). Refer to Figure A-5, page 75, and A-6, page 76.
- 3.7.5.1 The hard wired interlocks must be included whenever a microprocessor-based controller is used.
- 3.7.5.2 The interlocks must be used no matter what type of operation is designed for the system.
- 3.7.5.3 For closed transition, the overlap is to be less than 100 milliseconds. The separate timer located in the generator controls can be set for no longer than 0.250 seconds.

- 3.7.5.4 For extended closed transition, the timer can be set for no longer than 5 minutes. In addition, a reverse power relay (32), [or alternately, a directional overcurrent relay (67)], must be installed on the utility feed supplying the installation. The relay is to be selected from the approved list of relays noted earlier in this book.
- 3.7.6 If the autotransfer switch uses a microprocessor controller, then the hardwired interlock timing circuits cannot be implemented within the logic of the microprocessor controller. There must be a separate, independent timer. The design criteria must address the safe operation of the equipment for the complete failure of the main microprocessor controller.
- 3.7.7 If a design requires a variation of the above, including time intervals and relay setting, please contact PPL Electric Utilities.
- 3.7.8 Timer and relay Settings must be coordinated with PPL Electric Utilities prior to energization of the customer's facility.
- 3.7.9 Key Interlocks are acceptable for the proper sequenced control of operation of facilities by the customer.
- 3.8 Customer's bus at 12 kV, generator transfer at less than 600 volts
- 3.8.1 If the customer's bus is operated at 12 kV, but the transfer is at or below the 600 volt level, then the criteria within this section shall be applied appropriately. Refer to Figures A-7, A-8 and A-9, pages 77, 78 and 79, respectively, as examples and for additional information.
- 3.8.2 If the customer's bus is operated at 12 kV, and the transfer is made at 12 kV, please refer to Section 4 of this Appendix.
- 3.8.3 If utility supply is a two-line supply, the normally open point can be established at either of the two main circuit breakers or at the tie circuit breaker.
- 3.8.4 If closed transition schemes are implemented, the protection and control schemes must be designed to function and coordinate with the main, branch, and/or tie circuit breakers.
- 3.8.5 If extended closed transition schemes are implemented, the protection and control schemes must be designed to function and coordinate with the main, branch, and/or tie circuit breakers.
- 3.8.5.1 Reverse power relays (32), [or directional overcurrent relays (67)], must be included in the protection and control scheme to trip the appropriate circuit breaker for the malfunction of the transfer scheme.
- 3.8.5.2 The relay is to be selected from the accepted list of relays found on website: [Accepted Customer Point of Contact and Generator Intertie Protective Devices](#)

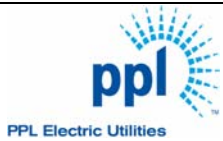

**TRANSMISSION PROTECTION & CONTROL
POINT OF CONTACT REQUIREMENTS FOR
CUSTOMER-OWNED FACILITIES (138 KV & 69 KV)**

EU00513844
Revision: 4
Effective Date: 10/1/2018
Sheet 69 of 86

- 3.8.6 Please review with PPL Electric Utilities prior to developing detailed engineering drawings.
- 3.8.7 Operational Issues for consideration
 - 3.8.7.1 The metering compartment is positioned after the main fault interrupting device and is to be in accordance with REMSI standards.
 - 3.8.7.2 Occasionally, PPL Electric Utilities personnel may need to adjust or replace the metering voltage transformer or the current transformer. This work is performed deenergized, with ground points on each side of the work area.
 - 3.8.7.3 If the customer needs to run their generation during that time to support the plant process, then consideration should be given to the installation of disconnect switches. This is shown on Figures A-7, A-8, and A-9 and labeled as item 2. This switch is an optional device from PPL Electric Utilities' standpoint. The decision to install additional disconnect points or switches is based on customer operational criteria.



**TRANSMISSION PROTECTION & CONTROL
POINT OF CONTACT REQUIREMENTS FOR
CUSTOMER-OWNED FACILITIES (138 KV & 69 KV)**

EU00513844
Revision: 4
Effective Date: 10/1/2018
Sheet 70 of 86

3.9 The following table summarizes the above information.

<u>Type of Equipment</u>		<u>Type of Interlocks and Protective Equipment</u>						
	<u>Transition</u>	<u>None</u>	<u>Hard Wired Interlock</u>	<u>Hard Wired Interlock /Timer 250 ms</u>	<u>Hard Wired Interlock /Timer 5 min</u>	<u>Reverse Power Relay (32)</u>	<u>Reference Paragraph</u>	<u>Reference Figure</u>
Manual double throw switch	Open	X					3.5.1 3.6.1 3.7.1	A-1
Autotransfer Switch, mechanically held	Open	X					3.5.1 3.6.2 3.7.1	A-1
Autotransfer circuit breaker, mechanically held	Open	X					3.5.1 3.6.3 3.7.2 3.7.3	A-3
Autotransfer Switch, mechanically held, <100 msec	Closed			X			3.5.2 3.6.2 3.7.4	A-4
Autotransfer, electrical circuit breakers, with microprocessor controller	Open		X				3.5.1 3.6.4 3.7.5	A-2
Autotransfer, electrical circuit breakers, with microprocessor controller, <100 msec	Closed			X			3.5.2 3.6.4 3.7.5.3	A-5
Autotransfer, electrical circuit breakers, with microprocessor controller, <5 minutes	Extended Closed				X	X	3.5.3 3.6.4 3.7.5.4	A-6

FIGURE A-1
BREAK-BEFORE-MAKE (OPEN TRANSITION)
UNDER 600 VOLTS

REFER TO REMSI SKETCH 41 SERIES

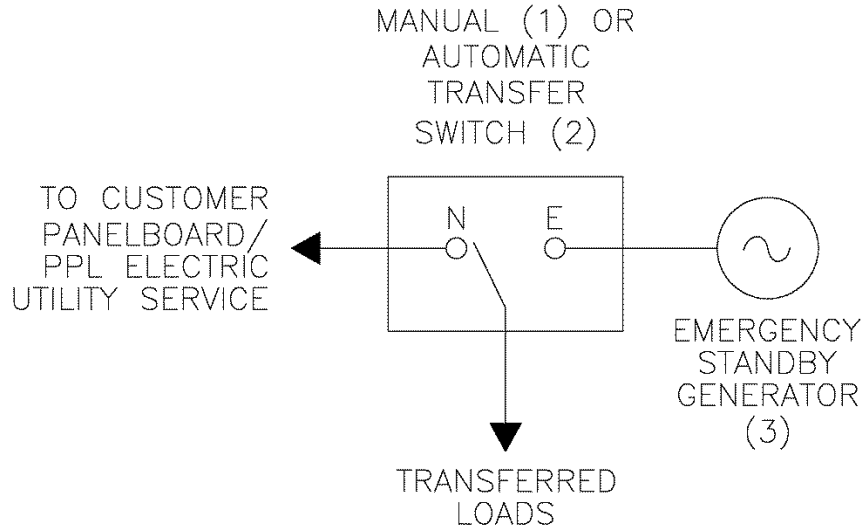

Legend:

- (1) Manual double throw switch appropriately sized for this application. De-energized operation is recommended.
- (2) Automatic transfer switch (ATS), appropriately sized for the application. Open transition (break-before-make). Electrically operated, mechanically held, no parallel operation of the utility source with the generator set. Autotransfer switch must be included on the list of acceptable autotransfer switch equipment.
- (3) Emergency standby generator may have integral overcurrent protection.

Notes:

1. Please contact PPL EU for acceptability of equipment before proceeding with engineering and material/equipment purchase.
2. Inspection and/or witness of performance tests are required for proper autotransfer switch connection and operation.

FIGURE A-2

**BREAK-BEFORE-MAKE (OPEN TRANSITION)
UNDER 600 VOLTS**

USING MOLDED CASE CIRCUIT BREAKERS AND ELECTRONIC
CONTROLLER (ELECTRICAL INTERLOCK)

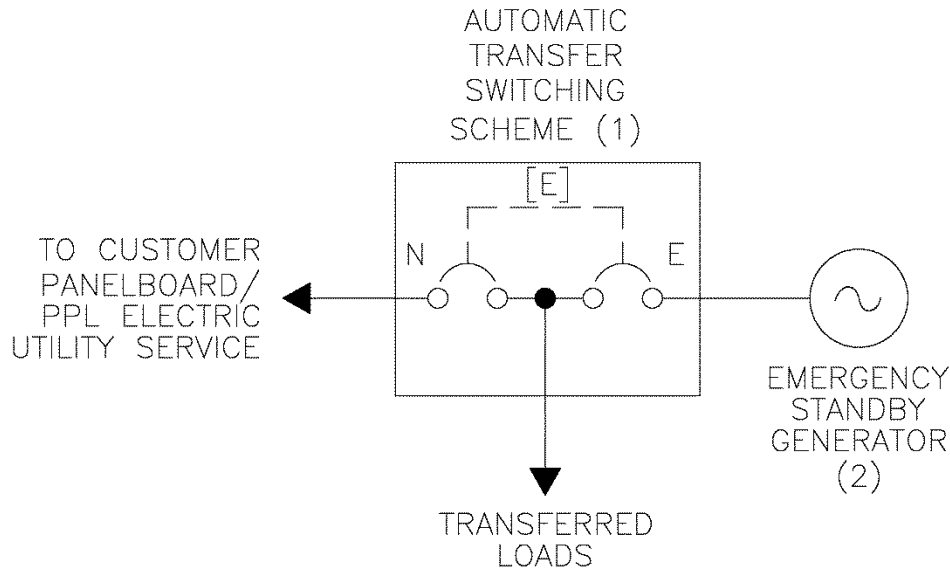

Legend:

- (1) Automatic transfer switch (ATS), appropriately sized for the application. Open transition (break-before-make, with molded case circuit breaker and electronic controller, and interlocked electrically to prevent parallel operation of the utility source with the generator set.
- (2) Emergency standby generator may have integral overcurrent protection.

Notes:

- 1. Please contact PPL EU for acceptability of equipment before proceeding with engineering and material/equipment purchase.
- 2. Inspection and/or witness of performance tests are required for proper autotransfer switch connection and operation.

FIGURE A-3

**BREAK-BEFORE-MAKE (OPEN TRANSITION)
UNDER 600 VOLTS**

USING MOLDED CASE CIRCUIT BREAKERS AND ELECTRICAL
OPERATOR (MECHANICAL INTERLOCK)

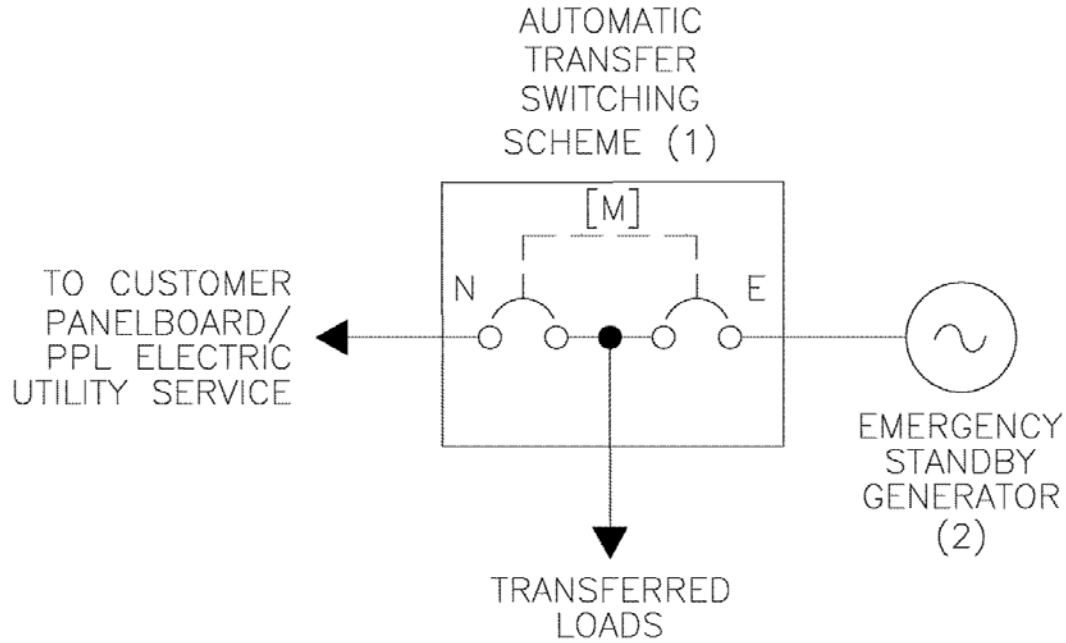

Legend:

- (1) Automatic transfer switch (ATS), appropriately sized for the application. Open transition (break-before-make), with molded case circuit breaker and electrical operator, interlocked mechanically to prevent parallel operation of the utility source with the generator set.
- (2) Emergency standby generator may have integral overcurrent protection.

Notes:

- 1. Please contact PPL EU for acceptability of equipment before proceeding with engineering and material/equipment purchase.
- 2. Inspection and/or witness of performance tests are required for proper autotransfer switch connection and operation.

**FIGURE A-4
MAKE-BEFORE-BREAK (CLOSED TRANSITION)
UNDER 600 VOLTS**

OVERLAP LESS THAN 100 MILLISECONDS

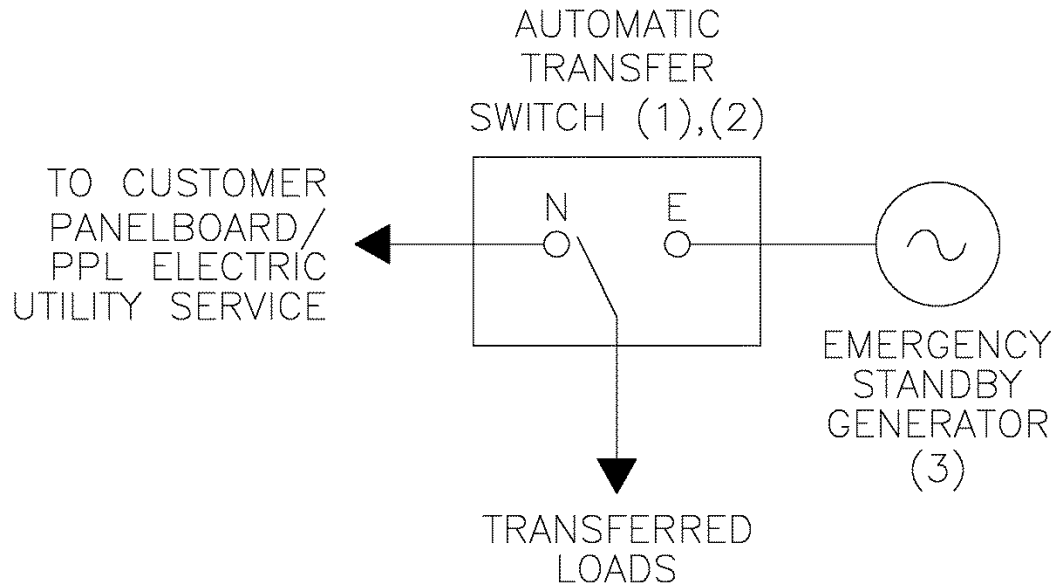

Legend:

- (1) Automatic transfer switch (ATS), appropriately sized for the application. Closed transition (make-before-break).
- (2) Closed transition must be less than 100 milliseconds.
- (3) Emergency standby generator may have integral overcurrent protection, tripped by the autotransfer switch timer.

Notes:

1. Please contact PPL EU for acceptability of equipment before proceeding with engineering and material/equipment purchase.
2. Inspection and/or witness of performance tests are required for proper autotransfer switch connection and operation.

FIGURE A-5

**MAKE-BEFORE-BREAK (CLOSED TRANSITION)
UNDER 600 VOLTS**

USING MOLDED CASE CIRCUIT BREAKERS AND ELECTRONIC CONTROLLERS
OVERLAP LESS THAN 100 MILLISECONDS

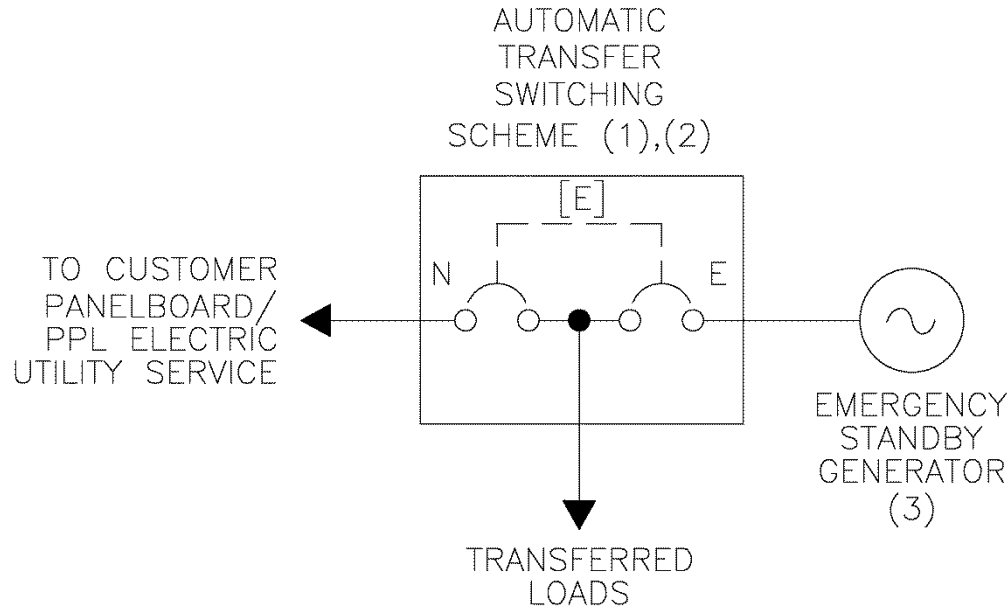

Legend:

- (1) Automatic transfer switch (ATS), appropriately sized for the application. Closed transition (make-before-break), with molded case circuit breaker and electronic microprocessor controller, hard wired electrical interlock scheme to prevent extended parallel operation of the utility source with the generator set.
- (2) Closed transition must be less than 100 milliseconds.
- (3) Emergency standby generator may have integral overcurrent protection, tripped by the autotransfer switch timer.

Notes:

1. Please contact PPL EU for acceptability of equipment before proceeding with engineering and material/equipment purchase.
2. Inspection and/or witness of performance tests are required for proper autotransfer switch connection and operation.

FIGURE A-6

**MAKE-BEFORE-BREAK (CLOSED TRANSITION)
UNDER 600 VOLTS**

USING MOLDED CASE CIRCUIT BREAKERS AND ELECTRONIC CONTROLLERS
OVERLAP LESS THAN 5 MINUTES

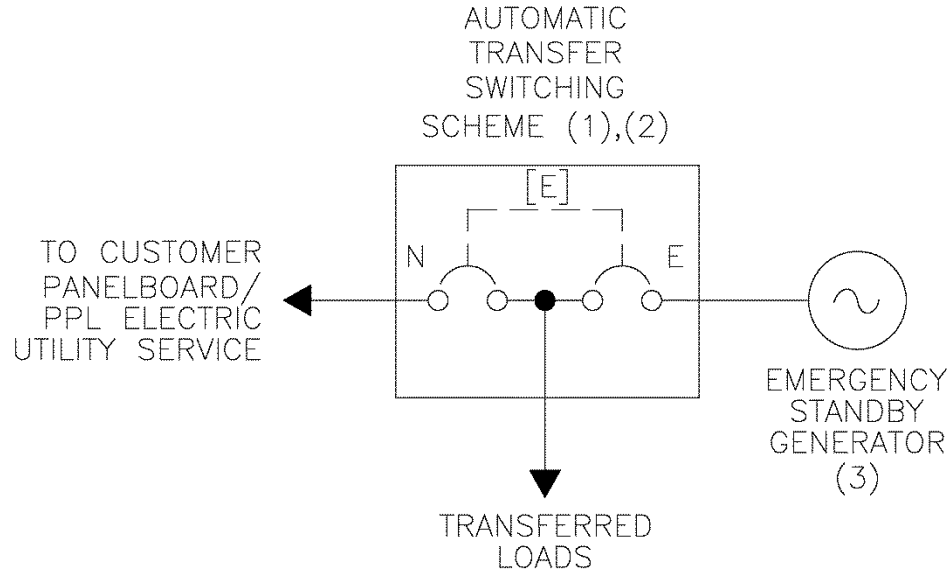

Legend:

- (1) Automatic transfer switch (ATS), appropriately sized for the application. Closed transition (make-before-break), with molded case circuit breaker and electronic microprocessor controller, hard wired electrical interlock scheme to prevent extended parallel operation of the utility source with the generator set.
- (2) Closed and overlapping transition must be less than 5 minutes.
- (3) Emergency standby generator may have integral overcurrent protection.

Notes:

1. Please contact PPL EU for acceptability of equipment before proceeding with engineering and material/equipment purchase.
2. Inspection and/or witness of performance tests are required for proper autotransfer switch connection and operation.

FIGURE A-7

CUSTOMER 12KV BUS -- LOW VOLTAGE TRANSFER

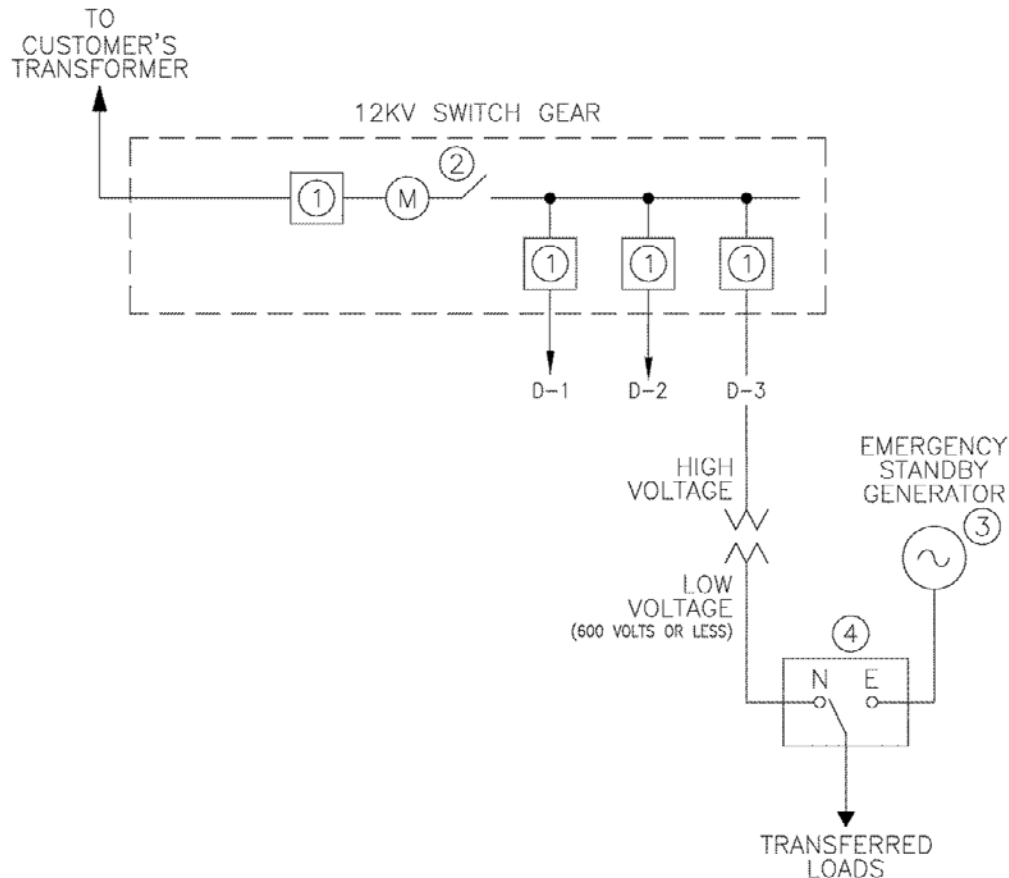

Legend:

- (M) Metering equipment (refer to REMSI for more information).
- (1) Fault interrupting device can be a fuse or a circuit breaker.
- (2) Disconnect point or switch—optional per customer criteria.
- (3) Emergency standby generator may have integral overcurrent protection.
- (4) Transfer switch appropriately sized for the application. Transfer can be open transition (break-before-make) (preferred), or closed transition (make-before-break). If closed transition, overlap time must be less than 100 milliseconds. Appropriate upstream fault interruption device as needed.

Notes:

1. Please contact PPL EU for acceptability of equipment before proceeding with engineering and material/equipment purchase.
2. Inspection and/or witness of performance tests are required for proper autotransfer switch connection and operation.

FIGURE A-8

CUSTOMER 12 KV BUSES -- LOW VOLTAGE TRANSFER

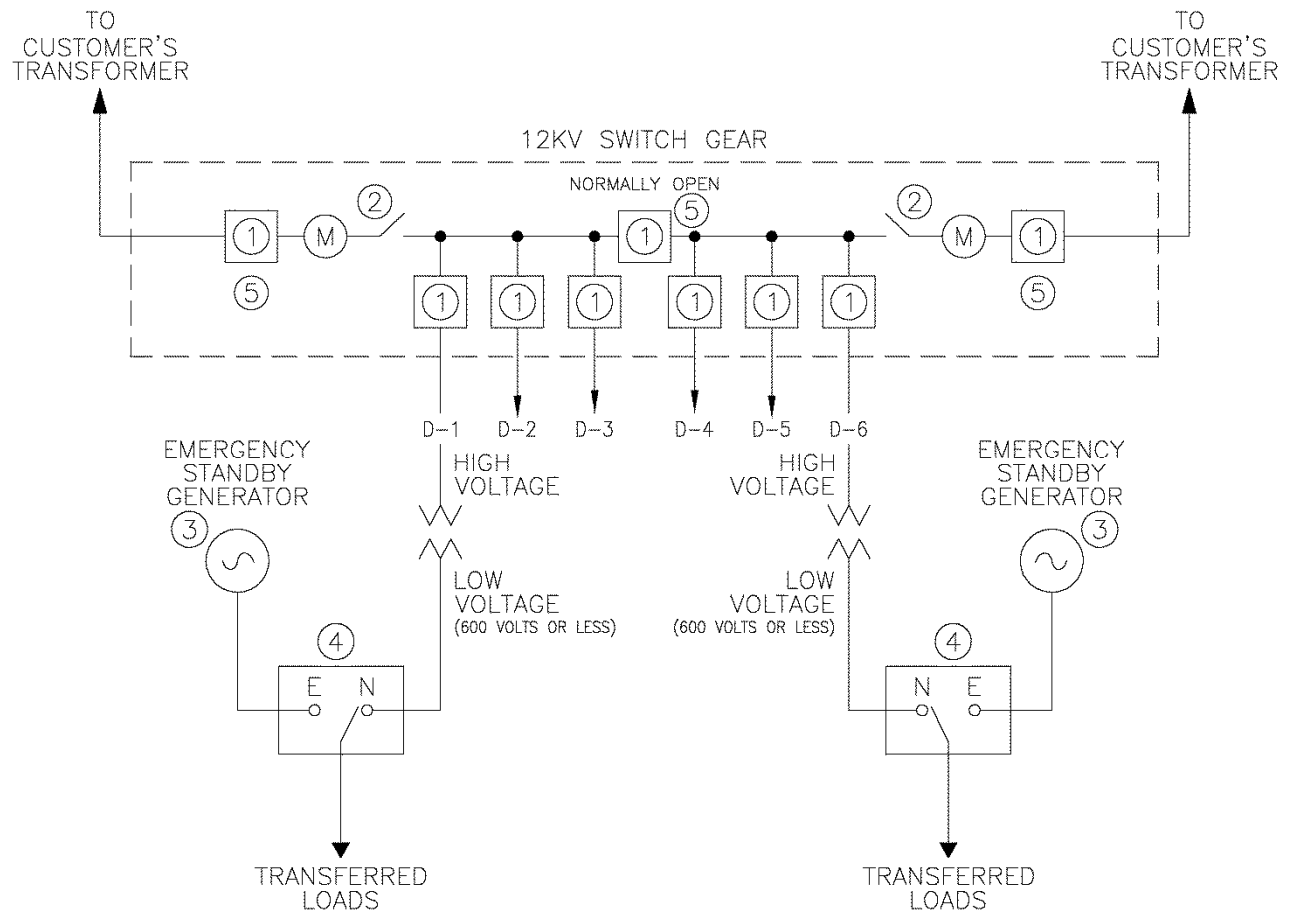

Legend:

- (M) Metering equipment (refer to REMSI for more information).
- (1) Fault interrupting device can be a fuse or a circuit breaker.
- (2) Disconnect point or switch—optional per customer criteria.
- (3) Emergency standby generator(s) may have integral overcurrent protection.
- (4) Transfer switch appropriately sized for the application. Transfer can be open transition (break-before-make) (preferred), or closed transition (make-before-break). If closed transition, overlap time must be less than 100 milliseconds. Appropriate upstream fault interruption devices as needed.
- (5) Normally open point can be the tie circuit breaker or either of the main circuit breakers.

Notes:

1. Please contact PPL EU for acceptability of equipment before proceeding with engineering and material/equipment purchase.
2. Inspection and/or witness of performance tests are required for proper autotransfer switch connection and operation.

**FIGURE A-9
CUSTOMER 12 KV BUSES -- LOW VOLTAGE TRANSFER**

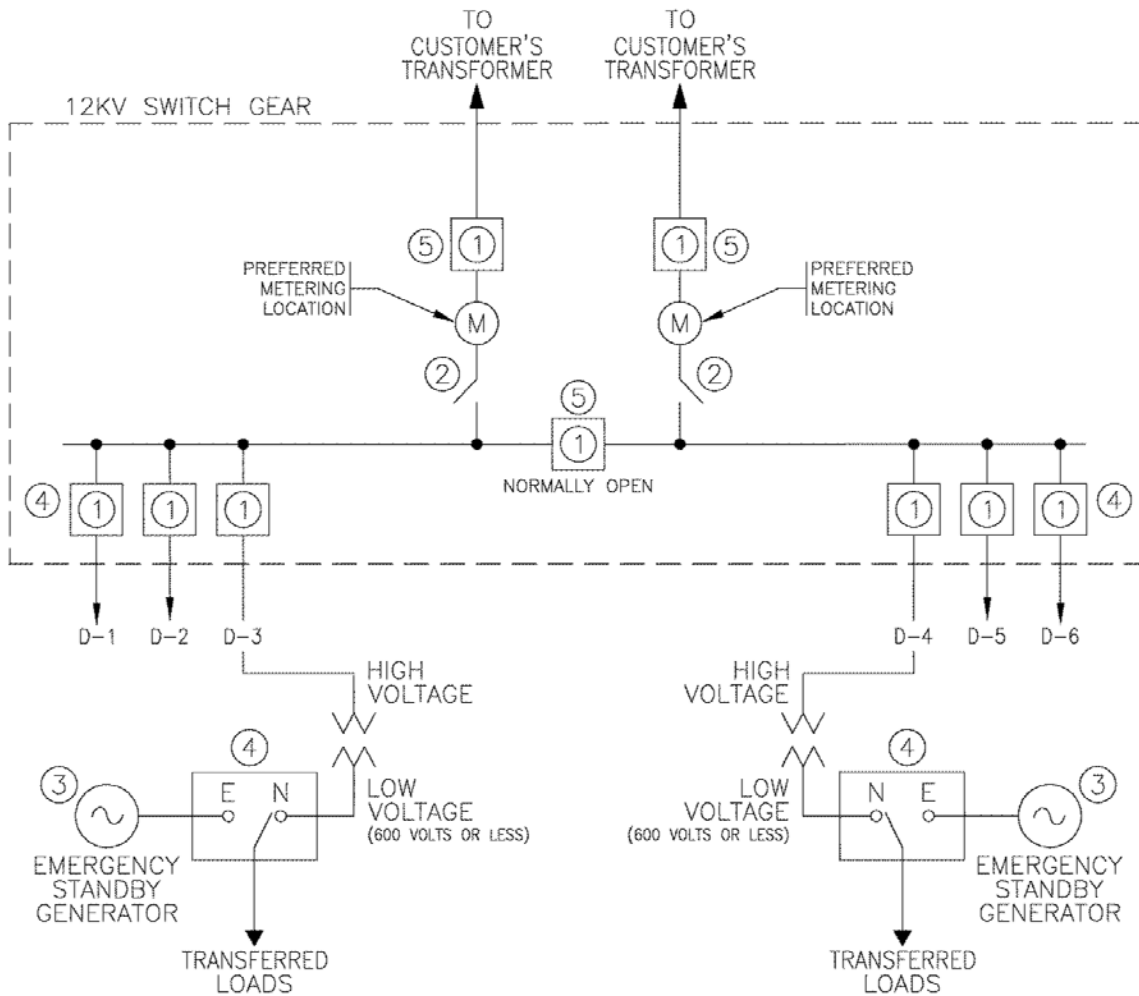

Legend:

- (M) Metering equipment (refer to REMSI for more information).
- (1) Fault interrupting device can be a fuse or a circuit breaker.
- (2) Disconnect point or switch—optional per customer criteria.
- (3) Emergency standby generator(s) may have integral overcurrent protection.
- (4) Transfer switch appropriately sized for the application. Transfer can be open transition (break-before-make) (preferred), or closed transition (make-before-break). If closed transition, overlap time must be less than 100 milliseconds. Appropriate upstream fault interruption devices as needed.
- (5) Normally open point can be the tie circuit breaker or either of the main circuit breakers.

Notes:

1. Please contact PPL EU for acceptability of equipment before proceeding with engineering and material/equipment purchase.
2. Inspection and/or witness of performance tests are required for proper autotransfer switch connection and operation.

4.0 TRANSFERS AT 12 kV (15 kV NOMINAL)

- 4.1 If the customer's load bus is operated at a voltage level of 12 kV (nominal 15 kV) but the transfer with the generator-set is made at or below the 600 volt level, appropriately apply the criteria discussed in Appendix Section 3.0 above.
- 4.2 Please contact PPL Electric Utilities for any designs that are not included within the scope of the information in this book.
- 4.3 Figures A-10, A-11, and A-12, should be used as reference in this section.
- 4.4 **Categories of Transitions** - the following categories of transitions rated 12 kV are acceptable for use on installation and connections with the PPL Electric Utilities system. These include:
 - 4.4.1 Open Transition – break before make operation in transfers made in both the normal to emergency transitions, and the emergency to normal transition. This is the **preferred** transfer mode.
 - 4.4.2 Closed Transition – with overlap made between the customer's generator and the utility source. The overlap duration must be less than 100 milliseconds.
 - 4.4.3 Extended Closed Transition – with an extended overlap made between the customer's generator and the utility source. This extended overlap duration must be less than 5 minutes.
- 4.5 **Equipment for power transfers** – the following equipment can be used to facilitate the transfer between the utility and the customer's generator. The proper specification and design of the equipment and transfer scheme is the responsibility of the customer / customer consultant.
 - 4.5.1 Manually operated circuit breakers (may include key interlocks)
 - 4.5.2 Electrically operated circuit breakers with hard wired controls (may include key interlocks).
 - 4.5.3 Electrically operated circuit breakers with microprocessor controllers.
- 4.6 **Protection and Control Criteria**
 - 4.6.1 If the transfer scheme is operated manually / open transition, with manually operated circuit breakers, with key interlocks to prevent parallel connection of the utility supply and the customer's generator, then protection and control criteria is based solely on customer criteria. No additional protective devices or interlocks are need for design acceptance.
 - 4.6.2 If the transfer scheme is operated manually / open transition, with electrically operated circuit breakers, protection and control criteria must

- include hard-wired interlocks to prevent paralleling of the utility source with the customer's generator.
- 4.6.3 If the transfer scheme is auto transfer / open transition, protection and control criteria must include hard-wired interlocks to prevent paralleling of the utility source with the customer's generator.
- 4.6.4 If the auto transfer switch is developed with electrically operated circuit breakers, controlled with a microprocessor controller, then hard wired interlocks with timer, wired from the auxiliary switches on each circuit breaker, must be included to prevent paralleling of the customer's generator with the utility to remain beyond the maximum allowed interval (as described below).
- 4.6.4.1 The hard wired interlocks must be included whenever a microprocessor based controller is used.
- 4.6.4.2 The interlocks must be used no matter what type of operation is designed for the system.
- 4.6.4.3 For closed transition, the allowed overlap must be less than 100 milliseconds. The separate timer located in the generator controls must be set for less than 0.250 seconds.
- 4.6.4.4 For extended closed transition, the timer can be no longer than 5 minutes. In addition, a reverse power relay (32), [or directional overcurrent relay (67)], must be installed on the utility feed supplying the installation. The relay is to be selected from the approved list of relays found at website: [Accepted Customer Point of Contact and Generator Intertie Protective Devices](#).
- 4.6.5 If a design requires a variation of the above, including time intervals and relay setting, please contact PPL Electric Utilities.
- 4.6.6 Timer and relay settings must be coordinated with PPL Electric Utilities prior to energization of the customer's facility.
- 4.6.7 Key Interlocks are acceptable for the proper sequenced control of operation of facilities.
- 4.7 Customer's bus at 12 kV, Generator transfer at 12 kV
- 4.7.1 Note: If the customer's bus is operated at 12 kV, but the transfer is made at or below the 600 volt level, then the criteria in Section 3 shall be applied appropriately. Refer to Figures A-7, A-8, and A-9.
- 4.7.2 If utility supply is a single line supply and transfer is made at 12 kV, refer to Figure A-10, page 85.

- 4.7.3 If utility supply is a two-line supply, and transfer is made at 12 kV, refer to Figure A-11, page 86, and Figure A-12, page 87. The normally open point can be established at either of the two main circuit breakers or at the tie circuit breaker.
- 4.7.4 If closed transition schemes are implemented, the protection and control schemes must be designed to function and coordinate with the main, branch, and/or tie circuit breakers.
- 4.7.5 If extended closed transition schemes are implemented, the protection and control schemes must be designed to function and coordinate with the main, branch, and/or tie circuit breakers.
- 4.7.5.1 Reverse power relays (32), [or directional overcurrent relay (67)], must be included in the protection and control scheme to trip the appropriate circuit breaker for the malfunction of the transfer scheme.
- 4.7.5.2 The relay is to be selected from the approved list of relays found at website: [Accepted Customer Point of Contact and Generator Intertie Protective Devices](#).
- 4.7.6 Please review with PPL Electric Utilities prior to developing detailed engineering drawings.
- 4.7.7 Operational Issues for consideration
- 4.7.7.1 The metering compartment is positioned after the main fault interrupting device and is to be in accordance with REMSI standards.
- 4.7.7.2 Occasionally, PPL Electric Utilities personnel may need to adjust or replace the metering voltage transformer or the current transformer. This work is performed de-energized, with temporary ground points on each side of the work area / metering devices.
- 4.7.7.3 If the customer needs to run their generation during that time to support the plant process, then consideration should be given to the installation of disconnect points or switches. This is shown on Figures A-10, A-11, and A-12 and labeled as item 2. This switch is an “optional” device from PPL Electric Utilities’ standpoint. The decision to install additional disconnect points or switches is based on customer operational criteria.

4.8 The following table summarizes the information of Section 4.

Type of Equipment	Type of Interlocks and Protective Equipment						
	<u>Transition</u>	<u>None</u>	<u>Hard Wired Interlock</u>	<u>Hard Wired Interlock /Timer 250 ms</u>	<u>Hard Wired Interlock /Timer 5 min</u>	<u>Reverse Power Relay (32)</u>	<u>Reference Paragraph</u>
Operated manually, with key interlocked circuit breakers	Open	X					4.4.1 4.5.1 4.6.1
Operated manually, with electrically controlled circuit breakers	Open		X				4.4.1 4.5.2 4.6.2
Autotransfer, electrical circuit breakers, with microprocessor controller	Open		X				4.4.1 4.5.3 4.6.3
Autotransfer, electrical circuit breakers, with microprocessor controller, <100 ms	Closed			X			4.4.2 4.5.3 4.6.4.3
Autotransfer, electrical circuit breakers, with microprocessor controller, <5minutes	Extended Closed				X	X	4.4.3 4.5.3 4.6.4.4

FIGURE A-10

CUSTOMER 12KV BUS -- TRANSFER AT 12KV

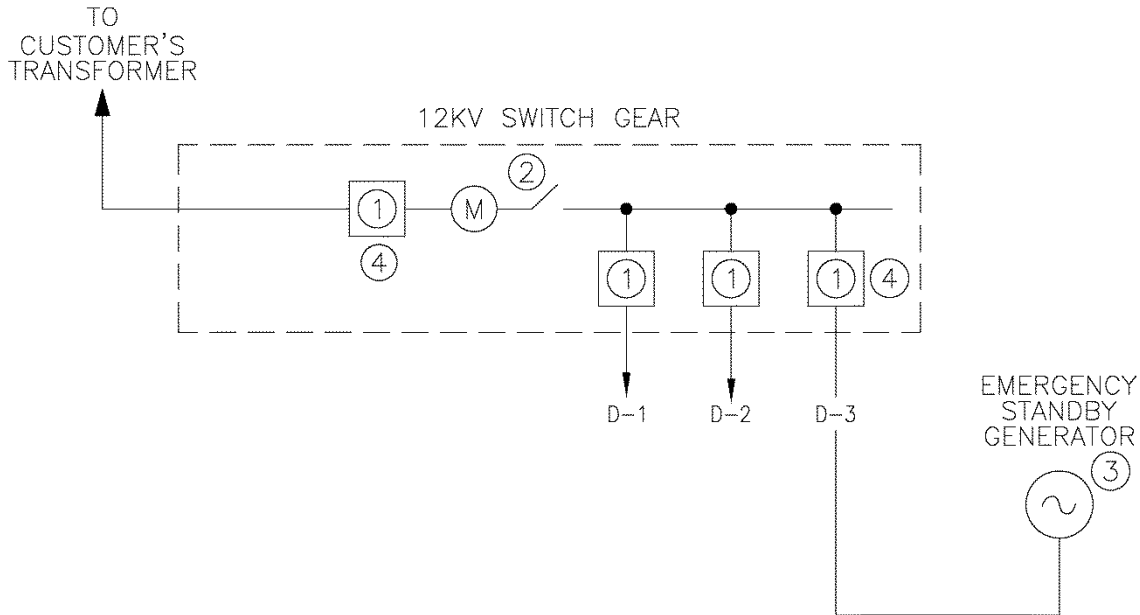

Legend:

- (M) Metering equipment (refer to REMSI for more information).
- (1) Fault interrupting device is a circuit breaker.
- (2) Disconnect point or switch—optional per customer criteria.
- (3) Emergency standby generator may have integral overcurrent protection.
- (4) Automatic transfer scheme with a circuit breaker. The transfer can be open transition (break-before-make) (preferred), or closed transition (make-before-break). If closed transition, overlap time must be less than 100 milliseconds. If extended closed transition, the overlap time must be less than 5 minutes. (Reverse power relay required for extended closed transition scheme.) Operational control interlocked with the main circuit breaker. Key interlocks are acceptable.

Notes:

1. Please contact PPL EU for acceptability of equipment before proceeding with engineering and material/equipment purchase.
2. Inspection and/or witness of performance tests are required for proper automatic transfer scheme operation.

FIGURE A-11

CUSTOMER 12KV BUSES -- TRANSFER AT 12KV

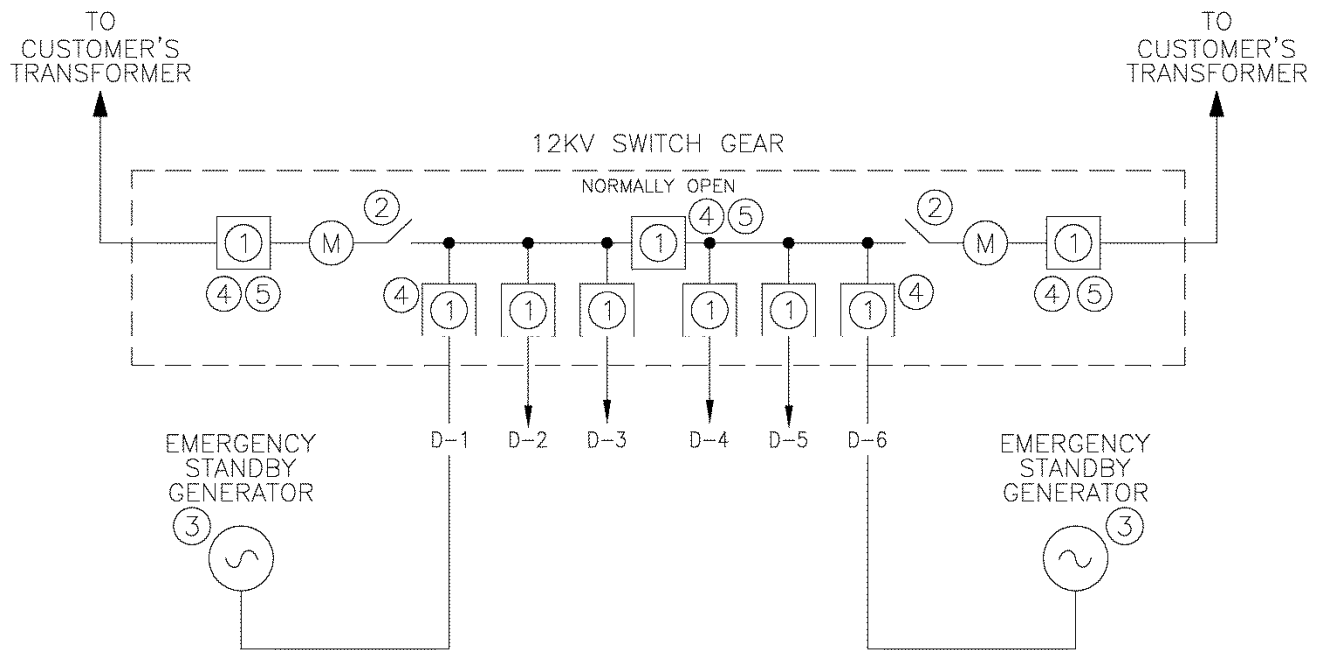

Legend:

- (M) Metering equipment (refer to REMSI for more information).
- (1) Fault interrupting device is a circuit breaker.
- (2) Disconnect point or switch—optional per customer criteria.
- (3) Emergency standby generator(s) may have integral overcurrent protection.
- (4) Automatic transfer scheme with a circuit breaker. The transfer can be open transition (break-before-make) (preferred), or closed transition (make-before-break). If closed transition, overlap time must be less than 100 milliseconds. If extended closed transition, the overlap time must be less than 5 minutes. (Reverse power relay required for extended closed transition scheme.) Operational control interlocked with the main and tie circuit breakers. Key interlocks are acceptable.
- (5) Normally open point can be the tie circuit breaker or either of the main circuit breakers.

Notes:

1. Please contact PPL EU for acceptability of equipment before proceeding with engineering and material/equipment purchase.
2. Inspection and/or witness of performance tests are required for proper automatic transfer scheme operation.

**FIGURE A-12
CUSTOMER 12KV BUSES -- TRANSFER AT 12KV**

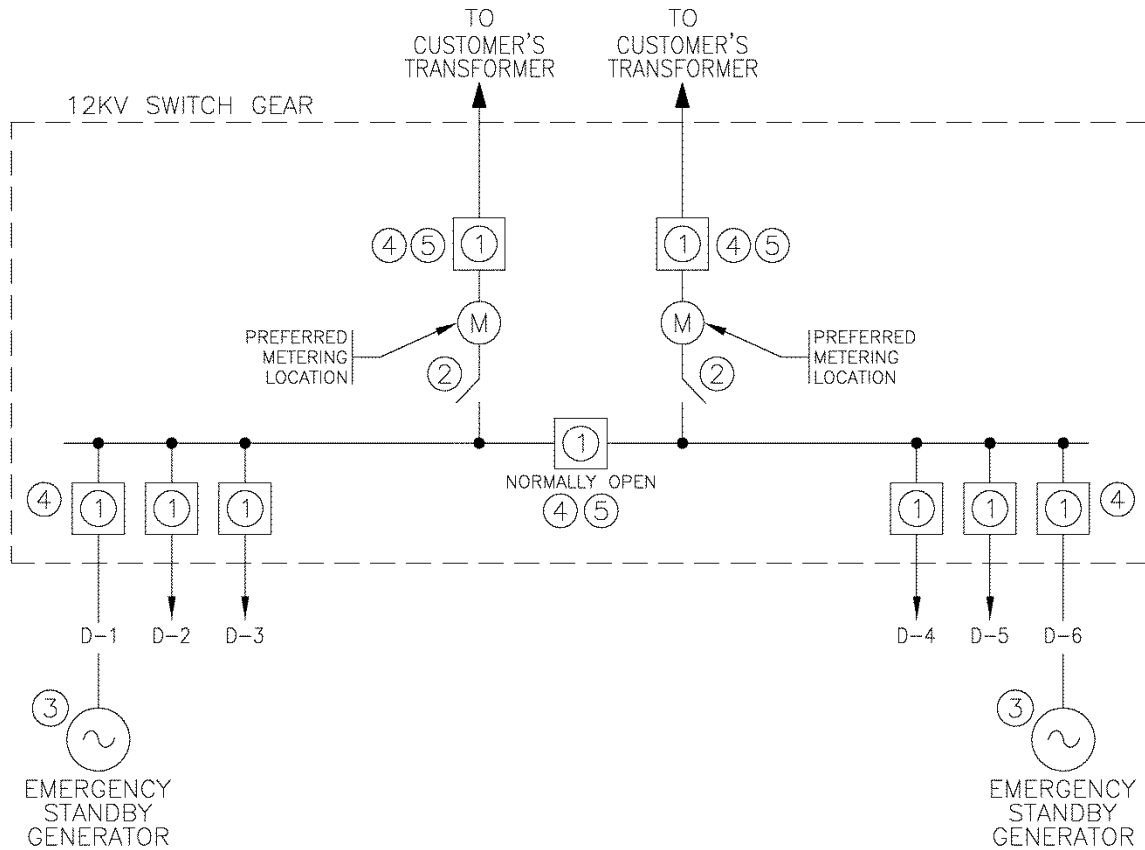

Legend:

- (M) Metering equipment (refer to REMSI for more information).
- (1) Fault interrupting device is a circuit breaker.
- (2) Disconnect point or switch—optional per customer criteria.
- (3) Emergency standby generator(s) may have integral overcurrent protection.
- (4) Automatic transfer scheme with a circuit breaker. The transfer can be open transition (break-before-make) (preferred), or closed transition (make-before-break). If closed transition, overlap time must be less than 100 milliseconds. If extended closed transition, the overlap time must be less than 5 minutes. (Reverse power relay required for extended closed transition scheme.) Operational control interlocked with the main and tie circuit breakers. Key interlocks are acceptable.
- (5) Normally open point can be the tie circuit breaker or either of the main circuit breakers.

Notes:

1. Please contact PPL EU for acceptability of equipment before proceeding with engineering and material/equipment purchase.
2. Inspection and/or witness of performance tests are required for proper automatic transfer scheme operation.